

TZ04

Dial Thermometer (Nitrogen-Filled Gauge)

- housing sizes from 63 to 250 mm
- stainless steel housing
- available with directly attached sensor or with capillary line
- temperature sensor and process connection individually configurable
- measuring range -200 ... +50 to 0 ... 800 °C
- alarm contacts optional
- accuracy: cl. 1,6; cl. 1,0 and cl. 0,6
-  Ex-Version acc. to ATEX optionally



Description:

Model series TZ04 dial thermometers feature a housing with integral gauge mechanism and a sensor system that is either attached directly or by means of a capillary tube.

The sensors are filled with neutral nitrogen, which transmits the temperature information. The gauge mechanism reacts to the pressure exerted by the nitrogen in the sensor system, causing corresponding movement of the gauge indicator needle.

Typical applications:

Because they are available in a variety of designs, TZ04 dial thermometers can be used in almost any kind of application where it is necessary to measure process temperatures by means of a local or remote gauge.

In addition, limit contacts or an optionally available temperature recorder (thermograph) allow the temperature information to be evaluated and upstream or downstream processes to be controlled.

Technical Data:

Materials: housing: stainless steel 1.4301 with bayonet ring, IP65
sight glass: mineral glass, 4 mm
scale: aluminium, white, black markings
pointer: aluminium, black
measuring unit: brass
temp. sensor: st. st. 1.4541
process connection: st. st. 1.4301

Limit contacts: see separate chapter (page 6)

Options: see table 8 (page 6)

Max. Process pressure

Without protective sleeve: min. 16 bar (depends on temperature, sensor diameter and length)

With protective sleeve: 25 bar (special models for higher pressures available on request)

Min. sensor length: see table 5, page 5

Different minimum sensor lengths are recommended, depending on the substance being monitored and the sensor diameter.

Example:

Sensor diameter: 10 mm

Monitored media:

Water: $L_{\min} = 60$ mm
Oil: $L_{\min} = 100$ mm
Air: $L_{\min} = 160$ mm

Max. sensor length: 3 m
(longer lengths available on request)

Max. sensor length: 40 m

Accuracy

NG 63, 80: Cl. 1,6
NG 100, 160, 250: Cl. 1,0
optional
NG 160, 250: Cl. 0,6

Overload protection: 30 % FS,
up to max. 800 °C
(optional 100 %)

Model Code:

Order number: TZ04. R. X. 100. L. A. 37. 0. 0. 9x90. BX1. 0. 0

Dial thermometer

Models:

R = with directly attached sensor
C = with capillary tube
S = special order

Housing materials:

X = st. steel

Housing diameter

63 = 63 mm
80 = 80 mm
100 = 100 mm
160 = 160 mm
250 = 250 mm
xxx = special order, please specify in writing

Damping:

X = unfilled (standard)
L = glycerine filled for vibration damping
S = silicone oil filled (increased vibrations damping)
K = oil filled, for devices with integrated limit contacts

Version (page 3):

A...H = see table 1

Measuring range (page 4):

1...47 = see table 2

Capillary tube (page 4):

0 = without
X...XP = see table 3

Capillary tube jacket (page 4):

0 = none
S...PB = see table 4

Sensor (page 5):

DxL = sensor diameter x sensor length
see table 5

Process connection (page 5):

BX1...CS3X6 = see table 6

Electrical output signals (page 6):

0 = without
M...TT2 = see table 7

Options (page 6):

multiple selection possible
0 = without
A...L = see table 8

Models:

R = thermometer with directly attached sensor

C = thermometer with capillary tube

Materials:

of
Aluminium scale, white with black markings
Aluminium indicator, black gauge mechanism, brass

X = Housing: st. st. 1.4301 with bayonet ring, IP65

Sight glass: mineral glass, 4 mm

Scale: aluminium with black markings

Pointer: aluminium, black

Measuring unit: brass

Temp. sensor: st. st. 1.4541

Process conn.: st. st. 1.4301

Housing diameter:

Nominal size: Ø 63, 80, 100, 160, 250 mm

**Special design:
(on request)** square housing
72x72, 96x96,
144x144, 192x192,
72x144 vertical or horizontal,
96x192 vertical or horizontal
temperature recorder (thermograph),
square:
192 x192, 288x288 mm,
round: d = 260 mm

Damping:

X = unfilled

L = filled with glycerine for vibration damping

S = Filled with silicone oil (increased vibration damping)

K = Filled with oil (for devices with integrated limit contacts)

Version (table 1):

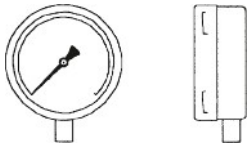
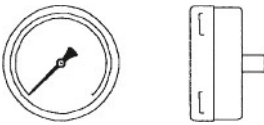
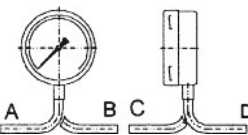
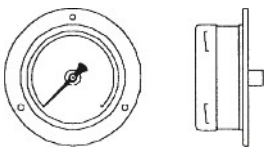
With directly attached sensor			
	Connection on bottom		A
	Connection on back in centre		E
	Connection on bottom, with 90° angle (A...D: direction of 90° angle)		T
	Connection on back, in centre with rim flange		F

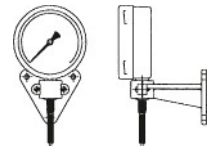
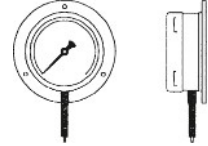
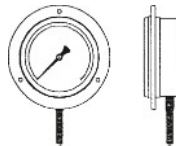
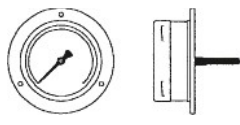
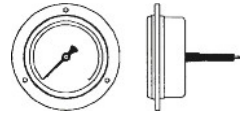
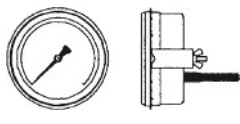
With capillary tube			
	Connection on bottom with wall mounting bracket		AW
	Connection on bottom with rim flange on back for wall mounting		B
	Connection on bottom with rim flange at front for installation in control panel		D
	Connection on back in centre with rim flange on back		F
	Connection on back in centre with rim flange at front		G
	Connection on back, not centered with three-angle front ring and retainer for installation in control panel		H

Measuring Ranges (Table 2):

No.	Range [°C]	Scale [°C]		Comment
		Class 1,0 and 1,6	Class 0,6 (Option)	
1	-200...+50	5	2	Option
2	-120...+40	2	1	Option
3	-110...+50	5	1	Option
4	-100...+100	5	1	Option
5	-100...+50	5	1	Option
6	-80...+40	2	1	Option
7	-60...+40	2	0,5	Option
8	-60...+60	2	1	Option
9	-50...+50	2	0,5	Option
10	-40...+20	1	0,5	Option
11	-40...+40	1	0,5	Standard
12	-40...+60	2	0,5	Option
13	-40...+80	2	1	Option
14	40...+110	5	1	Option
15	-40...+120	2	0,5	Option
16	-40...+160	5	1	Option
17	-30...+30	1	0,5	Standard
18	-30...+50	1	0,5	Option
19	-30...+70	2	0,5	Option
20	-30...+170	5	1	Option
21	-20...+40	1	0,5	Option
22	-20...+60	1	0,5	Option
23	-20...+80	2	0,5	Option
24	-20...+100	2	1	Option
25	-20...+120	2	1	Option
26	-20...+180	5	1	Option
27	-15...+45	1	0,5	Option
28	-10...+15	0,5	0,2	for sizes 72x144 and 96x192 only
29	-10...+30	1	0,2	
30	-10...+50	1	0,5	Option
31	-10...+110	2	1	Option
32	-10...+150	5	1	Option
33	0...+25	0,5	0,2	for sizes 72x144 and 96x192 only
34	0...+40	1	0,2	
35	0...+60	1	0,5	Standard
36	0...+80	1	0,5	Option
37	0...+100	2	0,5	Standard
38	0...+120	2	1	Standard
39	0...+160	5	1	Standard
40	0...+200	5	1	Option
41	0...+250	5	2	Option
42	0...+300	5	2	Option
43	0...+400	10	2	Option
44	0...+500	10	5	Option
45	0...+600	10	5	Option
46	0...+700	10	5	Option
47	0...+800	10	5	Option

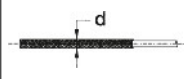

Capillary Tube (Table 3):

only for TZ04.C...

	Material	d [mm]	T _{min} [°C]	T _{max} [°C]	Code
	St. steel 1.4541	2,5	-260	800	X
	St. steel with PVC-coating	4	-60	120	XP

Capillary Tube (Table 4):

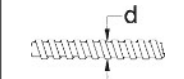
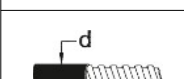
only for TZ04.C...

	Material	d [mm]	T _{min} [°C]	T _{max} [°C]	Code
	Flexible, st. steel 1.4301	6	-260	800	S
	Flexible, st. steel 1.4301 with PVC-coating	7,5	-60	120	SP
	Flexible, st. steel 1.4401	6	-260	800	X
	Flexible, st. steel 1.4401 with PVC-coating	7,5	-60	120	XP

Sensor:



The temperature sensors are all made of stainless steel 1.4541. The minimum sensor length is limited by dimension L_s (see Table 5). This length is the sensitive section of the sensor, which has to be immersed in the gas or liquid being monitored.

When ordering a thermometer, please use the following format to describe it:

Sensor diameter x sensor length (in mm)

Example: 10 x 200

Sensor Dimensions (Table 5):

Possible sensor diameters and minimum sensor lengths L_s [mm]					
		TZ04.R sensor directly attached minimum sensor length: $L = L_s$			
		TZ04.C with capillary tube, minimum sensor length: $L = L_s$			
Sensor diameter [mm]	Standard-Thermometer			Thermometer with alarm contact	
	TZ04.R sensor directly attached	TZ04.C with capillary tube up to 5 m	TZ04.C with capillary tube up to 5 m	TZ04.R measuring range >100 °C	TZ04.C capillary tube over 5 m
6	190	190	-	-	-
6,35	155	155	-	-	-
7	125	125	-	-	-
8	90	90	170	170	170
9	68	68	130	130	130
10	55	55	100	100	100
11	45	45	80	80	80
12	35	35	65	65	65
12,5	35	35	60	60	60
13	35	35	65	65	65
14	30	30	50	50	50
15	25	25	45	45	45
16	25	25	40	40	40
18	20	20	35	35	35
20	20	20	31	31	31

Process Connection (table 6):

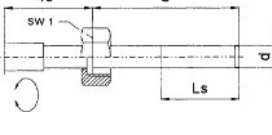
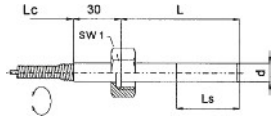
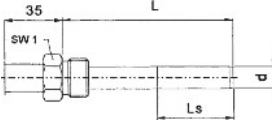
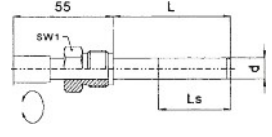
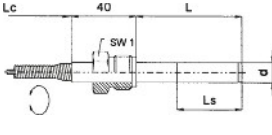
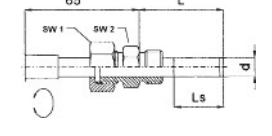
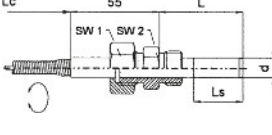
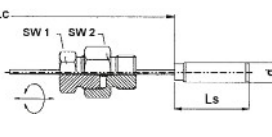
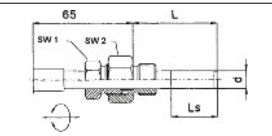
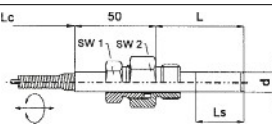
Material: st. st. 1.4301	Design	Connection	Code:
	With union nut for TZ04.R and TZ04.C	1/2" BSP	BX1
		3/4" BSP	BX2
		1" BSP	BX3
	With fixed nipple for TZ04.R	1/2" BSP	CX1
		3/4" BSP	CX2
		1" BSP	CX3
		1/2" NPT	CX4
		3/4" NPT	CX5
		1" NPT	CX6
	With rotating nipple for TZ04.R and TZ04.C	1/2" BSP	A04X1
		3/4" BSP	A04X2
		1" BSP	A04X3
	With double nipple and union nut for TZ04.R and TZ04.C	1/2" BSP	B01X1
		3/4" BSP	B01X2
		1" BSP	B01X3
		1/2" NPT	B01X4
		3/4" NPT	B01X5
		1" NPT	B01X6
	With double nipple and union nut, can be slid on capillary tube for TZ04.C	1/2" BSP	CS2X1
		3/4" BSP	CS2X2
		1" BSP	CS2X3
		1/2" NPT	CS2X4
		3/4" NPT	CS2X5
		1" NPT	CS2X6
	With double nipple and union nut, can be slid on sensor for TZ04.R and TZ04.C	1/2" BSP	CS3X1
		3/4" BSP	CS3X2
		1" BSP	CS3X3
		1/2" NPT	CS3X4
		3/4" NPT	CS3X5
		1" NPT	CS3X6

Additional process connections (on request):

Metric thread, hygienic dairy coupling, Tri-Clamp, surface sensor, spiral sensor for air, etc.

Limit Contacts:

Limit contacts are used to signal the overshooting or undershooting of certain temperature thresholds. Model TZ04 thermometers with round housing sizes of 100 and 160 mm or square housings can have up to four integral magnet spring or inductive contacts fitted in their housings. These contacts will be either of the normally open (N/O) or normally closed (N/C) type (in each case, based on increasing temperature).

Models (table 7):

Magnet spring contacts (30 W / 50 VA)		
x = 1: N/O x = 2: N/C x = 3: SPDT	For round housing diameters of 100, 160 mm, and square housing dimensions 96x96, 144x144, 72x144 mm	
1 contact	N/C or N/O	Mx
2 contacts	N/C, N/O or 2 SPDT	Mxx
3 contacts	N/C or N/O not for 72x144 housing	Mxxx
4 contacts	N/C or N/O not for 72x144 housing	Mxxxx
Inductive contacts acc. to NAMUR (requires intrinsically safe contact protection relay)		
1 contact	N/C or N/O	Ix
2 contacts	N/C or N/O or 2 SPDT	Ixx
3 contacts	N/C or N/O not for 72x144 housing	Ixxx

Options (table 8):

Housing of st. steel 1.4401 instead of 1.4301	for TZ04...X...	A
Sight glass made of safety glass	from NG 100	B
Non-return indicator needle, key reset	for devices without contact	C
Non-return indicator needle, key reset	for devices without contact	D
Micrometer indicator		E
Gauge mechanism and indicator needle made of st. steel 1.4301		F
Double scale: °C + °F		G
Precision measurement model, Cl. 0,6	only for diameters NG 160, 250 and 144x144, 192x192, 72x144 mm	H
Mirror scale	only with precision measurement model, only for diameters NG 160, 250	I
Polished sensor		K
HALAR-coated sensor	max. 1000 mm, max. 200 °C	L

Stainless Steel Sensor Protection Sleeves:

For sensors with A04, B, C and CS3 connections

Available on request.