

DTH04

Calorimetric Flow Transmitter and Switch in Ø12mm Housing

- for liquids
- short response time
- no moving parts
- independent of nominal sizes
- high temperature gradient
- insignificant pressure loss
- reliable monitoring in two measuring ranges of 2...150 cm/s and 3...300 cm/s
- P_{\max} : 40 bar, T_{\max} : 100 °C



Description:

The calorimetric measuring technology is based on the fact, that heat energy is transferred from the surface of the probe to the medium. The higher the velocity of the medium, the more heat energy is taken away by the medium. An unheated Pt100 resistance temperature detector (RTD) embedded in the stainless steel sensor tip serves to record the medium temperature. A second RTD is electrically heated and exposed to the flow. The temperature difference of these two RTDs is proportional to the flow velocity and therefore to the flow volume. For range two, when a value of about 300 cm/s is reached there is so much heat absorbed by the medium that both RTDs have almost the same temperature, and hence the upper limit of the measuring range, is reached.

The DTH04 is a compact device and consists of a stainless steel sensor and an integral electrical unit as standard. This can be configured as a switch-, voltage-, electrical-, frequency- or counting pulse output version.

Typical Applications:

The DTH04 units are designed for effective monitoring of liquid media. Because of the low flow resistance and their relative insensitivity to contamination by solids they offer a good alternative to paddle type devices. Because of their structural shape the flow switches are suitable for every pipe diameter.

Just a minimal flow velocity is required at the sensor tip. Calorimetric flow switches are widely used in the steel and metal working industries. As well as throughout the chemical and beverage sector. Typical applications are coolant monitoring for welding robots, plasma-pumps or cooling units, dry run protection for pumps, and water monitoring in sprinkler systems.

Models:

Process connection:

The universally popular and versatile compression fitting has been adopted as standard. The connection is available in brass or stainless steel. It is equipped with a metal ferrule or PTFE compression gland. It is also possible to deliver the devices ready mounted in a T-piece made of brass or stainless steel (P1N10 with GFR POM seal). In this case the calibration in l/min can be done directly. As an option there is also an integrated inlet and outlet pipe available. The calibration can be done in l/min directly, too.

Sensors:

The sensors are integrated into the complete device, available lengths are: 123, 173 and 223 mm.

Output:

In the switch, frequency- and pulse output versions, the devices are equipped with a push-pull transistor output. The analogue output version provides 0...10 V, or 4...20 mA signals. The switch output is programmable through a "teach-in" function on site.

Electrical connection:

The DTH04 is equipped with an M12 x 1, 4-pole plug system.

Electrical Data:

Voltage supply:	24 VDC ± 10 %
Power consumption:	50 mA no-load condition
Connection:	M12x1, 4-pole plug
Protection system:	IP67, reverse polarity protected, and short-circuit proof
Output:	switch, frequency, pulse output: push-pull transistor, max 50 mA pulse output with 50 ms width
	analogue output: 0...10 V, min 1 kOhm 4...20 mA, max 500 Ohm

With an analogue or pulse output signal, the nominal pipe bore has to be specified.

Technical Data:

Max. pressure:	40 bar (580 psi) with thread 10 bar with compression fitting 10 bar all others
Media temp. range:	-20 °C to 70 °C, optional 100 °C
Ambient temperature:	0 °C to 70 °C (32 °F to 158 °F)
Housing:	stainless steel 1.4571 T-piece st. steel. or brass, POM seal
Connection:	G1/2 male thread compression fitting
Measuring ranges:	2 to 150 cm/s and 3 to 300 cm/s
Accuracy:	+/- 10% F.S., when calibrated in T-piece: 5%, repeatability: 1% temperature gradient: +/- 0,01 %/K < 3 seconds
Response time:	< 3 seconds
Weight:	about 50 g without fittings

Dimensions:

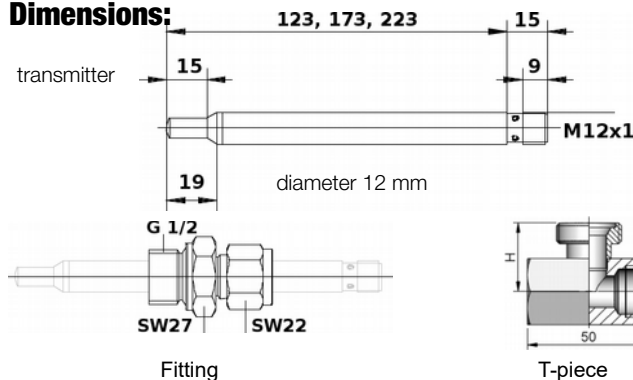

Size	G 1/2	G 3/4	G 1	G 1 1/4	G 1 1/2	G 2
H [mm]	28	29	33	37	40	49

Model Code:

Order Number: DTH04. 1. U. 1. 1. GF. 15. 0

Calorimetric Flow Transmitter and Switch

Measuring range:

1 = 2...150 cm/s (standard)
3 = 3...300 cm/s

Output signal for flow:

SL = 1 switching output, minimum switch
SH = 1 switching output, maximum switch
I = 4...20 mA analogue output
U = 0...10 V analogue output
F = frequency output, please specify desired fmax value (2000 Hz max)
Z = counting pulse, please specify pulse valence, (only in combination with T-piece or inlet pipe)

Electrical connection:

1 = M12x1 plug, 4 pole

Sensor length:

1 = 123 mm
2 = 173 mm
3 = 223 mm

Process connection:

GF = plain pipe without thread
TM = with T-piece of brass
calibration in l/min
TV = with T-piece of stainless steel
calibration in l/min

Connection size:

00 = without thread
15 = G ½ female
20 = G ¾ female
25 = G 1 female
32 = G 1 ¼ female
40 = G 1 ½ female
50 = G 2 female

Options:

0 = none
HT = Tmax (medium) 100 °C

Accessories:

Compression fitting SVQ.V.15.P.12, G ½ female

material: stainless steel 1.4571, PTFE ring
Pmax: 25 bar, Tmax: 100 °C



M12x1 plug with PVC cable SM12.4 (4-pole)

straight or angled
different lengths
(please see data sheet SM12)

