

# DG01

## Flow Indicator with and without Rotor, with Wipers for Cleaning of Sight Glass

- for liquids and gases
- small mounting dimensions
- design in brass or stainless steel
- may be installed in any position
- optionally with or without rotor for visual flow confirmation
- with internal wiper blades for easy cleaning of the sight glass
- 360° visible
- max. pressure 16 bar, max. temperature 100 °C



### Description:

The flow indicator of the model series DG01 are designed to display the flow through a pipe system. The flowing gas or liquid can be monitored through a sight glass. A rotor that is set in motion by the gas or liquid to provide visual confirmation of flow is available as an option. Wiper blades mounted in the flow indicator are pressed against the inside of the sight glass. The inside of the sight glass can easily be cleaned of deposits, algae or calcification by simply rotating it by hand. This design feature allows regular cleaning without having to interrupt the process being monitored, making time-consuming and costly maintenance and cleaning unnecessary (no downtime).

### Typical applications:

The flow indicators DG01 are used for monitoring in pipelines. The version of the DG01 with ball bearings is also suitable for use with gases.

## Models:

DG 01.x.1: without rotor  
 DG 01.x.2: with rotor

Materials: brass- or stainless steel version

## Nominal sizes and flow rates with rotor:

Connection <b>G</b>	Liquids				Air	
	Rotor start up [l/min]			Q <sub>max.</sub> recom.	Rotor start up [l/min] *	Q <sub>max.</sub> recom.
	H <sub>2</sub> O	40 mm <sup>2</sup> /s	41...150 mm <sup>2</sup> /s			
1/4	0,7	1,5	2,7	4	18	60
3/8	0,8		2,8	8	20	150
1/2	1,4	1,8	3,2	12	25	250
3/4		2,7	5,9	25	25	250
1	1,7	3,0	7,0	40	35	350
1 1/4	8,0	5,9	7,9	80	60	600
1 1/2		7,3		100	70	700

\* 1 bar abs, 20 °C

## Dimensions:

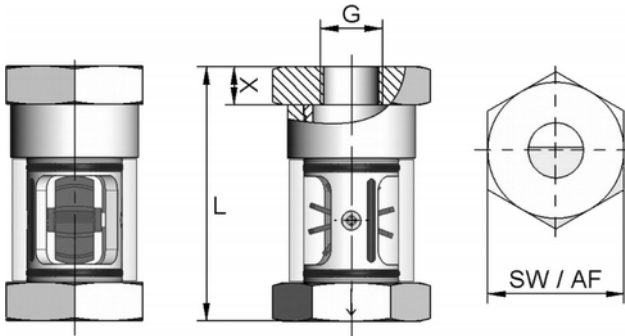

DG01.x. 1 (without rotor)				
Connection <b>G</b>	<b>L</b> [mm]	<b>SW</b> [mm]	<b>X</b> [mm]	<b>Weight</b> [kg]
1/4	71	36	9	0,3
3/8	71	36	9	0,3
1/2	86	46	13	0,6
3/4	94	46	16	0,6
1	104	46	16	0,6
1 1/4	120	65	19	1,5
1 1/2	130	65	20	1,6
DG01.x. 2 (with rotor)				
Connection <b>G</b>	<b>L</b> [mm]	<b>SW</b> [mm]	<b>X</b> [mm]	<b>Weight</b> [kg]
1/4	71	36	9	0,35
3/8	71	36	9	0,35
1/2	86	46	13	0,65
3/4	94	46	16	0,65
1	104	46	16	0,65
1 1/4	120	65	19	1,60
1 1/2	130	65	20	1,70

## Order Code:

Order number : **DG01.** **F.** **2.** **3.** **M.** **0**

Flow indicator with or without rotor, with wipers for cleaning of sight glass

### Medium:

F = liquids  
 G = gases

### Models:

1 = without rotor  
 2 = with rotor

### Connection:

1 = G 1/4 female thread  
 2 = G 3/8 female thread  
 3 = G 1/2 female thread  
 4 = G 3/4 female thread  
 5 = G 1 female thread  
 6 = G 1 1/4 female thread  
 7 = G 1 1/2 female thread

### Materials:

M = brass, nickel plated  
 E = stainless steel

### Options:

0 = without  
 9 = please specify in plain text

## Technical Data:

Max. pressure: 16 bar

### Medium-temperature:

DG01.x.1: -20 ... +100°C

DG01.x.2: 0 ... +100°C

Installation position: may be installed in any position

## Materials:

### Housing:

DG01.x.x.x.M: brass CW614N nickel plated  
 DG01.x.x.x.E: stainless steel 1.4305

### Sight glass:

borosilicate glass

### Wipers:

DG01.x.x.x.M: NBR  
 DG01.x.x.x.E: FKM

### O-Ring:

DG01.x.x.x.M: NBR  
 DG01.x.x.x.E: FKM

### Rotor: (DG01.x.2.x.x only)

DN 8-DN 25: POM, red  
 DN 32-DN 40: PA66, white

### Bearing:

for liquids: PEEK  
 for gases: steel 100 CR 6 chrome coated