



**PKP Prozessmesstechnik GmbH**  
**Borsigstrasse 24**  
**D-65205 Wiesbaden-Nordenstadt**  
**Tel.: 06122-7055 0**  
**Fax.: 06122-7055 50**

## Operating Instructions

**DZ01.15...DZ01.50**

Oil Counter

# Oil Flowmeter DN15...50 DZ01



## Table of contents

### General

Meter Configuration	14
Application, planning and installation	14
Safety precautions	14

### Plant design

Layout of piping	15
- Meter installation	15
- Correct layout of meter and accessories	15
- Stop valves or cocks	16
- Dirt filter, Safety filter	16
- Heat insulation	16
Special requirements pulsers, remote evaluation	17
Special requirements differential measurement	17
Special requirements - ships	17
- Installation on the suction side	18
- Draining pipes	18
Special requirements of filling, dosing units	18
Electrical installations layout	18

### Installing the meters

Preparing for installation	19
Installing the meter in the pipe	19
Electrical connections	20
- Safety precautions	20
- Wiring diagram	20
- Pulser, INA	21
- Pulser, RV	21
- Pulser, IN	21
Parameterising ancillary devices	22

### Operating instructions see part 2

### Commissioning

Putting the plant into operation	22
Check tightness	22
Check plant flow	22
Check function of connected accessories	22

### Servicing/repair

Safety precautions	23
Dirt filter	23
Maintenance, spare parts	23

### Dimensional drawings, technical data

Flow sensors	23
Transducer groups/Measurement transducers	24
Display / Roller counter	24

# General

## Meter configuration

DZ01 oil meters consist of a flow sensor and a measurement transducer with display, totaliser and signal outputs where applicable. The flow rate range determines the nominal size of the flow sensor. The measurement transducer is either one complete ("universal") unit or is a combination of complementary units (transducer group) which can be chosen to suite a particular application.

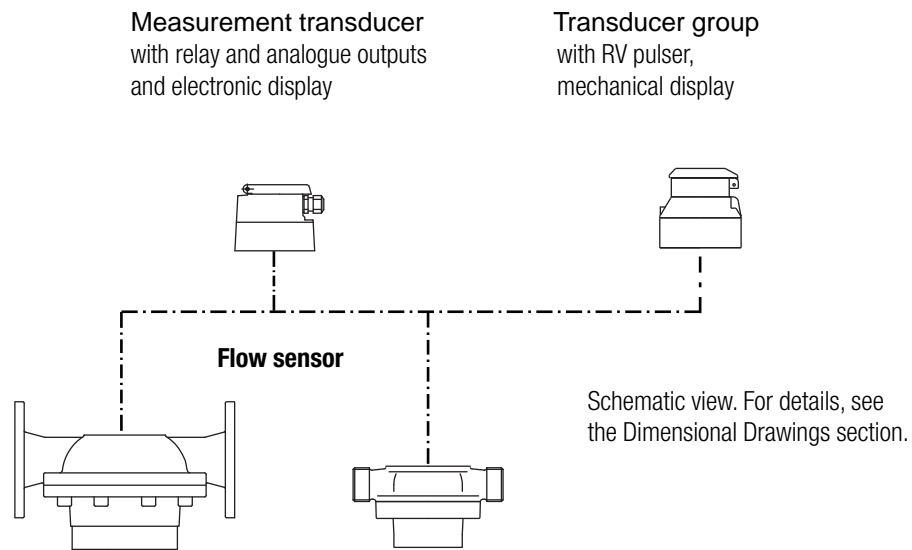

The flow sensor and the measurement transducer are calibrated jointly and form one metering unit. For optimal results for differential measurements, meters with special calibration should be used. If the measurement transducer is replaced at a later stage, a certain divergence in measured values is to be expected.

## Applications, planning and installation

DZ01 oil meters must only be used for their intended purpose and comply with safety regulations. Aquametro devices are manufactured according to valid standards and guidelines. Aquametro guarantees the quality of the product in the context of its General Terms of Business. The owner or operator will be liable for the correct installation as well as the appropriate handling of the equipment upon its receipt. The instructions for assembly and operation are to be followed exactly. None of the information stated here releases planners, installers and operators from their own careful and comprehensive assessment of the respective plant configuration in terms of functional capability and operational safety.

## Safety precautions

- The design of the plant must ensure that the meter cannot be damaged, especially from the effects of icing, torsion in the piping, excessive heat expansion of the piping, misaligned pipes during installation, intrusion of foreign bodies or silt-up.
- The clearance distance of the piping must be adhered to when mounting the meter. If using flanged connections, the correct number of connector elements must be fitted and they must be tightened with the correct torque in accordance with the screw manufacturer's instructions.
- Comply with the permissible operating data as defined on the type plate. Pressure test with a maximum of 1.5 x the nominal pressure (PN).
- Make sure that no hazardous fumes can build up in the piping and in the meter during commissioning, decommissioning and dismantling.
- The meter must at all times be completely filled with liquid during operation.
- Check the meter periodically for tightness of the connections and for proper functioning.
- If work is to be done on the installation, before each intervention:
  - a) release the pressure in the installation
  - b) if hazardous liquids are used, wear protective clothing and safety goggles
  - c) place a collecting tray underneath the installation.

# Plant design

## Layout of piping

### Meter installation

Easy access for reading the meter and controlling the ancillary equipment is important.

Provided that the arrow on the housing is in the direction of flow, the meter can be installed in any position without any special modifications. The display is adjusted to the installed position in situ.

Do not mount the meter with the head pointing downwards. Flow conditioners are unnecessary.

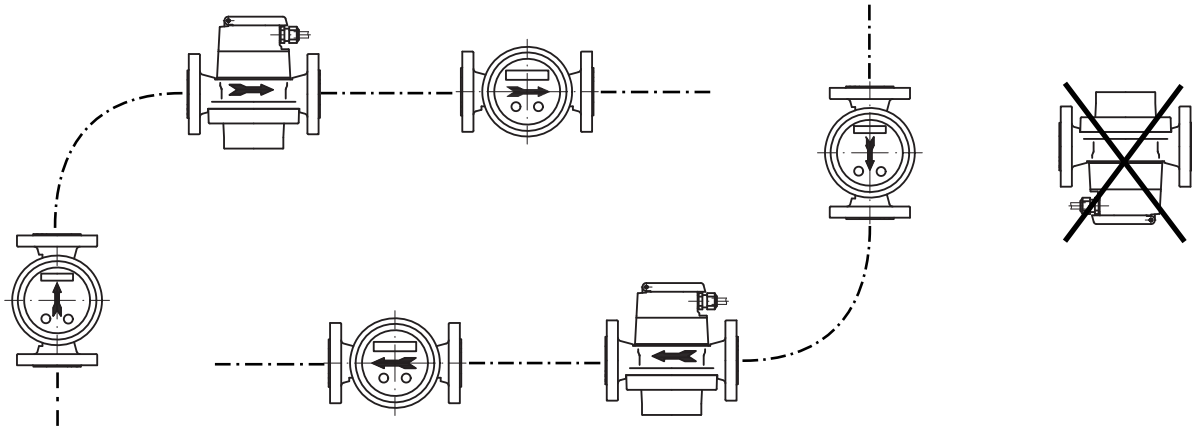

The layout of piping must ensure that the meter is filled with liquid at all times and that no inclusions of air or gas may occur.

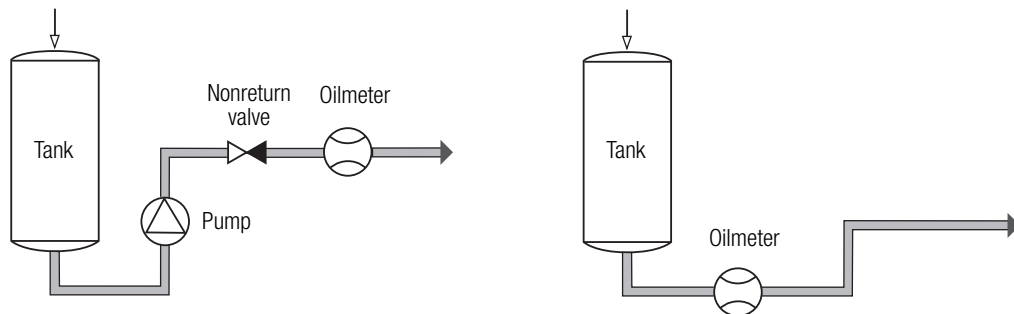

The quantities from all consumers must be registered by the meter.

### Correct layout of meter and accessories

If the meter is used for viscosities in excess of 5 mPa.s, or if it is mounted on the suction side of a pump, the pressure loss and the flow rate that can still be attained should be determined with the help of the pressure loss curves provided in Technical Information. In addition, the pressure loss due to installed filters must be taken into consideration.

Select the meter and ancillaries according to the max. working conditions.

- Operating pressure and temperature
- Ambient temperature  $-10^{\circ}\text{C} \dots 60^{\circ}\text{C}$
- Resistance of the material against: liquid to be metered, working conditions
- Flow rate

The meters are to be selected according to the flow rate and not according to the pipe diameter. If necessary, adapt the pipework.

### Stop valves or cocks

In order to avoid backflow and draining, stop valves must be mounted after the meter. Backflow and draining cause faulty measurements and may damage the meter.

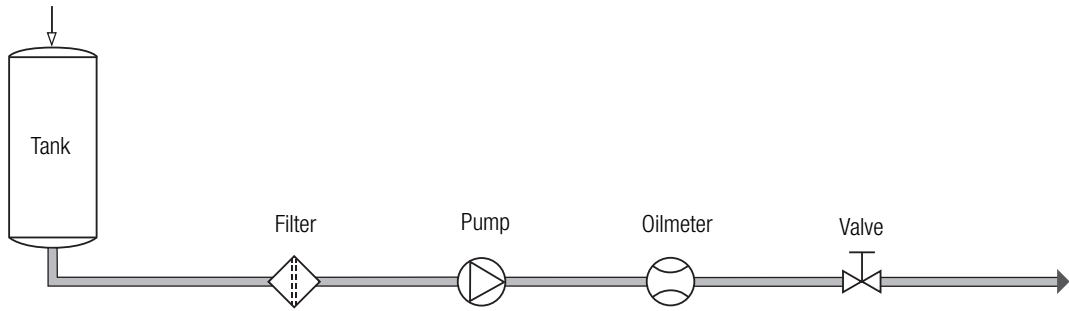

### Dirt filter, Safety filter

Filters should be fitted to prevent any damage to the meter from impurities in the liquid.

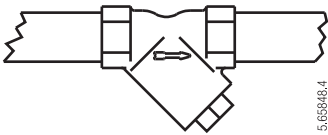

Maximum mesh width for filters		
Nominal size	Meter type	
	DZ01	DZ01.A
DN15	0,250 mm	0,100 mm
DN20	0,400 mm*	0,100 mm
DN25	0,400 mm*	0,250 mm
DN40	0,600 mm	0,250 mm
DN50	0,600 mm	0,250 mm

\* If a dirt filter with the given mesh size is used, the safety filter in the meter inlet can be removed.

The filter mounted in the meter inlet is only a safety filter and is too small to act as a dirt filter.

### Heat insulation

The measurement transducer must not be insulated. This could cause its permitted temperature range to be exceeded.

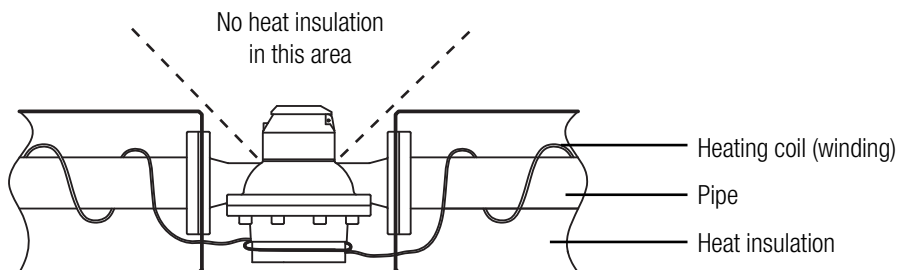

The permitted temperature ranges for the meter must be observed.

## Special requirements - pulsers for remote evaluation

Return flow must be avoided for meters equipped with RV, IN or INA pulsers for remote evaluation. If the plant design cannot ensure this, a nonreturn valve must be installed.

## Special requirements - differential measurements

For differential measurements, one meter is installed in the pipe for supply and return flow respectively. The difference between the supply and return flow volumes determines the consumption.

If ordered with the "differential measurement" option, **DZ01.A** meters are calibrated in accordance with the indicated supply and return flow volumes. Make sure that these meters are installed in the correct pipes, i.e. the supply flow meter should be installed in the pipe that supplies the consumer and the return flow meter should be installed in the return pipe.

## Special requirements - ships

On ships, attention is needed to ensure that the engine can continue to operate at full power even if there is heavy filter contamination or if the meter is damaged. A pressure switch can be used to switch over to the bypass and to draw attention to the need for servicing. The engine then continues to operate but without consumption measurements.

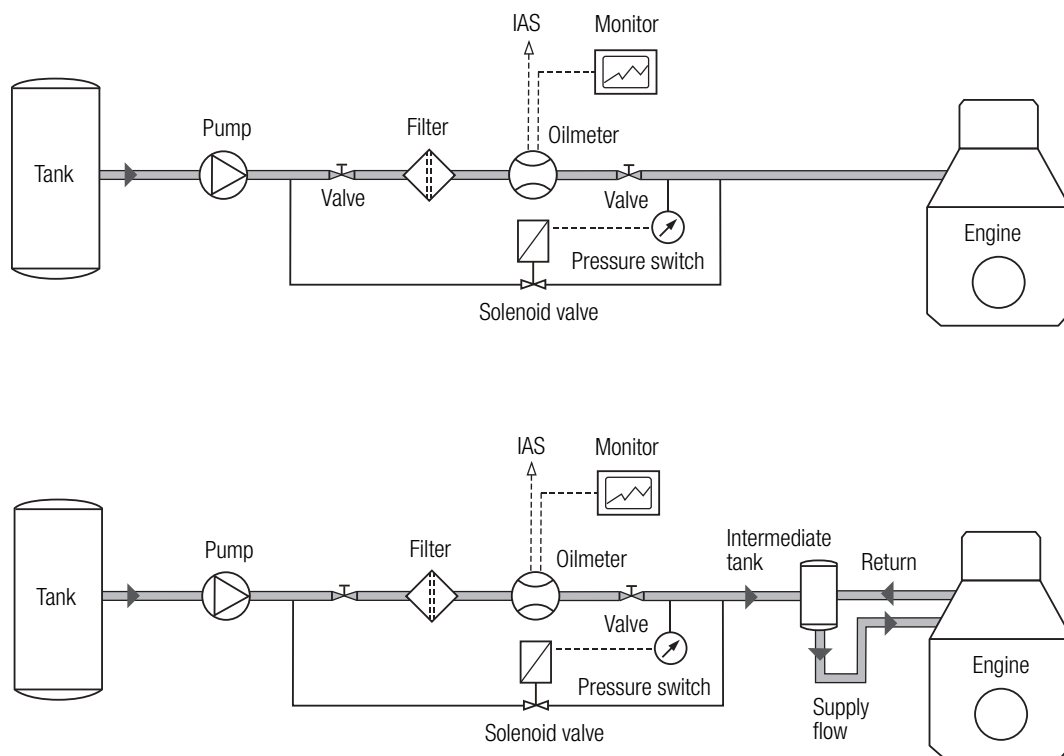

Ship classification societies require the installation of bypass pipes. The relevant regulations must be followed.

### Installation of the meter on the suction side of a pump

If the oil meter is installed on the suction side of a pump, consideration must be given to the maximum pressure loss at the maximum permitted flow rate and the maximum viscosity that occurs. Installed filters must also be taken into account.

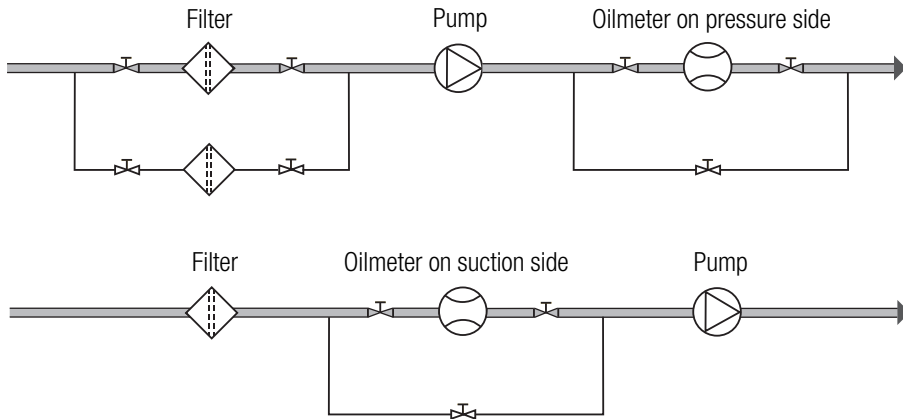

### Draining pipes

If the pipes are to be drained with compressed air at a later stage, stop valves must be provided on both sides of meter.

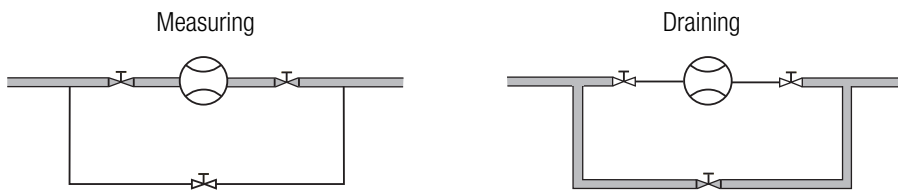

### Special requirements - filling and dosing units

For filling and dosing, the valve must be fitted between meter and discharge.

The shorter the pipe section between valve and discharge, the higher the accuracy. Fast opening and closing of the valve should be avoided as this can cause pressure or water hammer. Water hammer damages the meter.

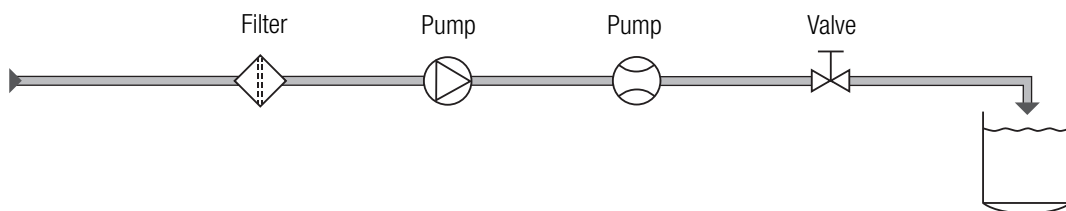

### Electrical installations

Electrical installations are subject to legal regulations which must be observed when planning the facility.

Electrical installations must only be carried out by authorised specialists.

In the layout of the installation, the following factors should be taken into account during plant design:

- ancillary devices connected to the meter
- maximum cable lengths with/without repeater
- junction boxes, cable guides
- environmental disturbances

Electrical installations are subject to special regulations, which require mandatory compliance.

# Installing the meters

## Preparing for installation

Check meters and installation material.

Compare the data of the meter with the expected maximum conditions of the installation. They may not exceed the meter specifications:

- Maximum flow rate ( $Q_{max}$  l/h)
- Maximum operating pressure (PN bar)
- Maximum temperature ( $^{\circ}C$ )
- Appropriate connections( threaded, or flanged) and seals (gaskets)
- Fasteners for the meter
- Resistance to liquid to be metered and temperature.

When existing plants are altered:

Flush the installation and put it out of operation. Close the stop valves of the section containing the meter.

Make sure that unauthorised start-up is not possible while mounting.

The applicable working regulations must be complied with during all work on the plant.

Prepare the pipe and connections for the meter in the specified length for installation, and install a matching intermediate piece with a dirttrap where appropriate.

Start trial operation; open the stop valves **slowly** when doing this.

- Carry out a pressure test in the plant.
- Check for leak tightness.
- Flush the pipework until no residues are left.
- Release the pressure and stop the plant again.

This trial operation ensures that the pipework is tight and clean.

## Installing the meter in the pipe

Remove the protection plugs or caps from the meter (inlet and outlet).

Measurement of heavy fuel oil with DZ01 20 or 25:

If a dirt filter with a mesh size of max. 0.5 mm is installed, the safety filter may be removed from the meter inlet to reduce the pressure loss.

Insert the meter into the pipeline in the prescribed position and flow direction. The arrow on the flow sensor should correspond with the direction of flow. Install mating flanges parallel and without tension in the pipe.

Meter with threaded ends

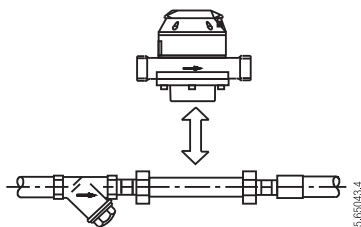

Meter with flanges

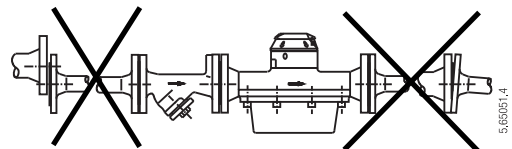
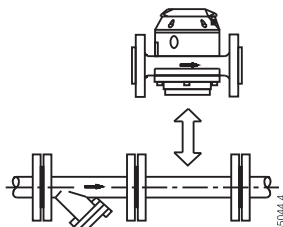

For pipes made of copper or thin-walled steel pipes, the meter requires additional fastening. Use appropriate fasteners.

If another pressure test is done after mounting the meter, the following pressures are acceptable for a short duration:

Nominal pressure (PN)	Maximum test pressure
16 bar	25 bar
25 bar	40 bar
40 bar	64 bar



## Electrical connections

### Safety precautions

Disconnect from power supply. Before working on electrical installations, make sure that nobody can power up the facility.

Pay attention to installation instructions for electrical devices:

- voltage, operation data
- maximum transmission length
- cable cross section, length
- ambient temperature, mounting position

### Wiring diagram DZ01

4 different output functions are available:

- Pulser for volume pulses with programmable pulse value (for external totaliser)
- Analogue current output 4...20 mA corresponding to flow rate
- Frequency output 0...100 Hz corresponding to flow rate
- Switching function (limiting value switch) specified by programmable upper and lower flow rates

Except for the analogue output function, any two of the remaining three functions can always be used simultaneously. This results in two types of connection; the desired one must be set in the Parameter Menu.

- 1 potential-free digital output (Rel.1), freely parameterisable to one of the three functions mentioned below.
- passive current output, 4...20 mA (Analog), used to power the meter at the same time.

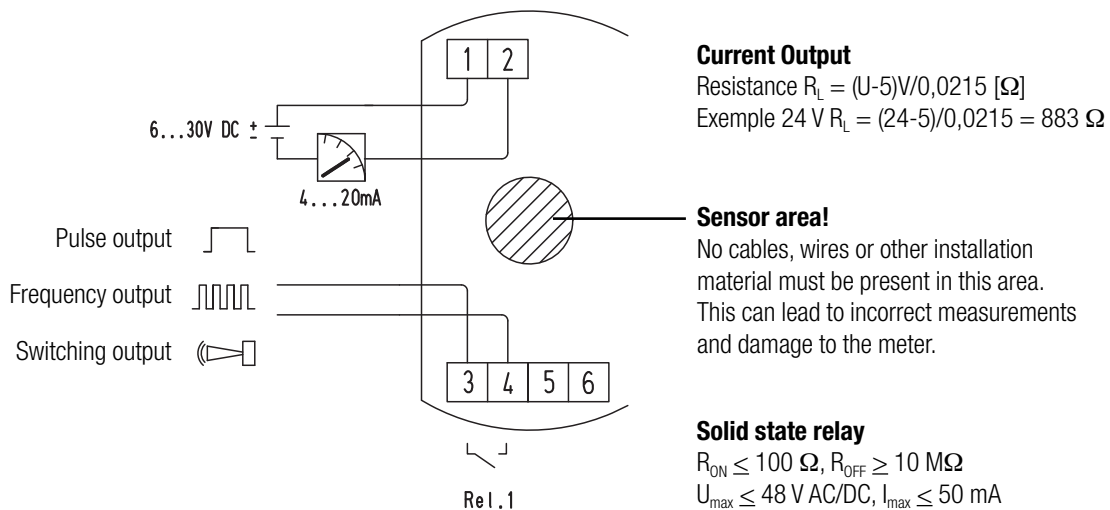

- 2 potential-free digital outputs (Rel.1+Rel.2), each freely parameterisable to one of the three functions mentioned below.
- the current output is not available here, but the power is provided via its terminals.

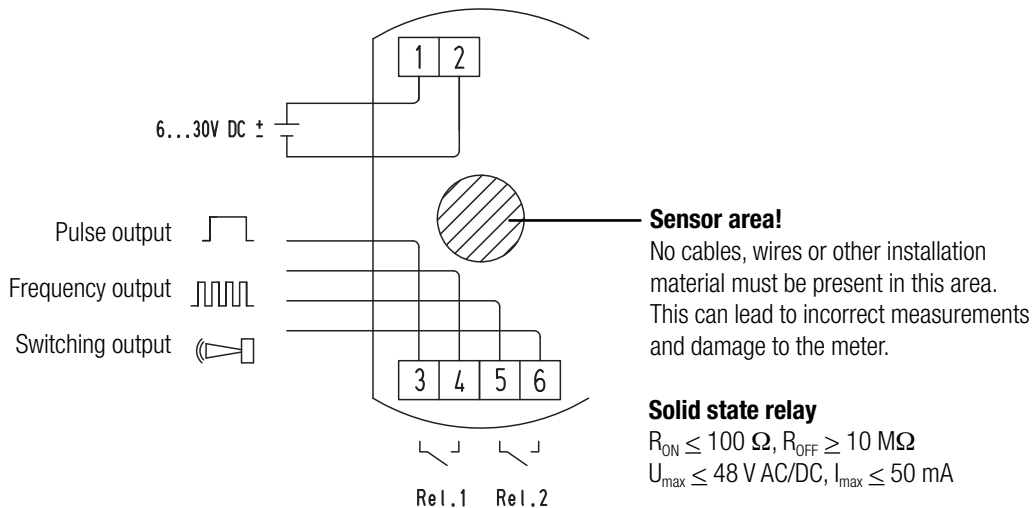

## Options

### RV type pulser

Cable; 3 m, Polarity: arbitrary

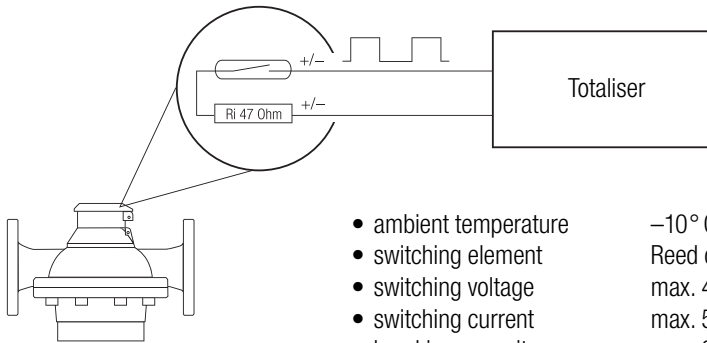

- |                       |                     |
|-----------------------|---------------------|
| • ambient temperature | -10° C ... 70° C    |
| • switching element   | Reed contact        |
| • switching voltage   | max. 48 V DC/AC     |
| • switching current   | max. 50 mA (Ri 47Ω) |
| • breaking capacity   | max. 2 W            |
| • quiescent current   | zero                |
| • pulse value         | see type plate      |

### IN type pulser

Pay attention to polarity when connecting the plug.

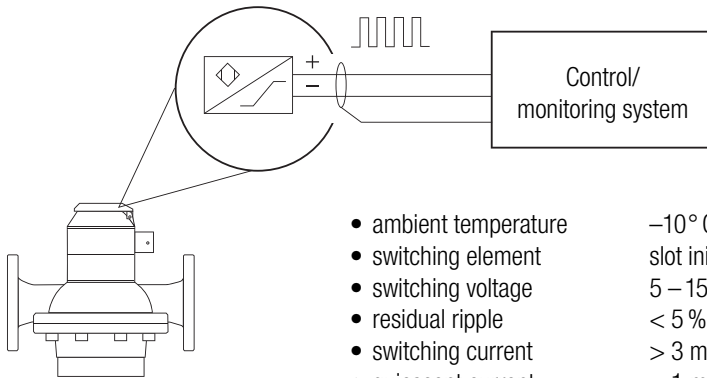

- |                       |  |
|-----------------------|--|
| • ambient temperature | -10° C ... 70° C   |
| • switching element   | slot initiator acc. to IEC 60947-5-6 (NAMUR)   |
| • switching voltage   | 5 – 15 V DC  |
| • residual ripple     | < 5 %  |
| • switching current   | > 3 mA (at 8 V, 1 kΩ)  |
| • quiescent current   | < 1 mA (at 8 V, 1 kΩ)  |
| • pulse value         | see type plate   |
| • connecting          | cable min. 2 x 0.35 mm <sup>2</sup> and 4...6 mm external diameter,<br>on plug supplied with product or use option part no.<br>80019 with cable mounted. |

Plug (IN and INA)

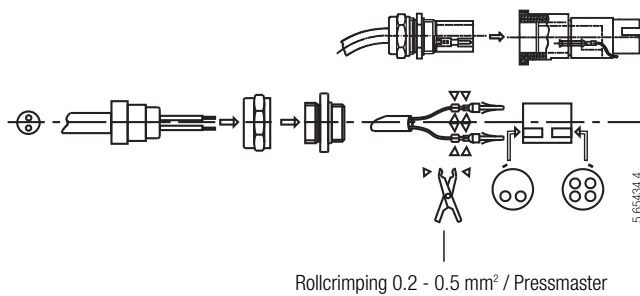

## Parameterising ancillary devices

Some ancillary units require programming of pulse values or frequency (see the relevant operating instructions).

Pulse values of the meters: see type plates.

The frequency is calculated with the following formula:

$$\frac{\text{max. flow rate in litres / hour}}{\text{pulse value in litres x 3600}} = \text{Frequency in Hz}$$

## Commissioning

### Putting the plant into operation

Open valves **slowly**, fill pipework gradually.

Vent the installation well.

Pressure shocks must be avoided in order not to damage the meter. Inclusions of air cause measuring errors in all types of meter and can damage them in operation.

### Check the tightness of the connections of the device.

### Check the flow rate of the installation.

Electronic display: read the instantaneous value

Roller counter type meter: measurement of flow volume for 30 ... 60 seconds

The flow rate is calculated using the following formula:

$$\frac{\text{Totalised volume in liters x 3600}}{\text{Measuring time in seconds}} = \text{Liters per hour}$$

Should the established flow rate be greater than the specification of the meter ( $Q_{\max}$ ), either a flow control valve (throttle) must be inserted behind the flow sensor or a larger size flow sensor must be used.

### Check function of connected accessories.

# Servicing / repairs

## Safety precautions

Before working on the hydraulics:

- put the plant or section out of operation
- close the stop valves
- release the pressure

To restart the plant:

- slowly open the stop valves, avoiding pressure surges ('water hammer')
- vent the pipe well
- check tightness

## Dirt filter

Dirt filters must be cleaned periodically, initially at short intervals.

## Maintenance, spare parts

Check connections periodically for tightness and if necessary tighten again. For control and cleaning, the measuring chamber and the ring piston of the meters DN15 ... 50 can be removed without dismantling the meter from the pipe.

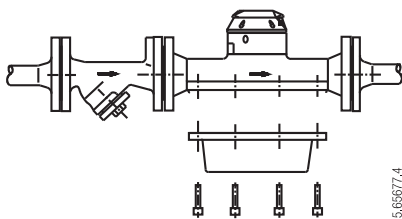

Torque of measuring chamber screws		
Flow meter	Screws	Torque
DN 15,20	M 6	6 Nm
DN 25	M 8	16 Nm
DN 40	M 12	47 Nm
DN 50	M 16	100 Nm

The cleaning and revision cycle depends largely on the conditions of operation. Under favourable conditions 5 ... 10 years suffice. Check the units for corrosion. When ancillary equipment is used, observe their mounting and operation instructions.

Spare part lists may be requested from Aquametro.

# Dimensional drawings

## Flow sensors

DN15, 20, 25: with threaded ends

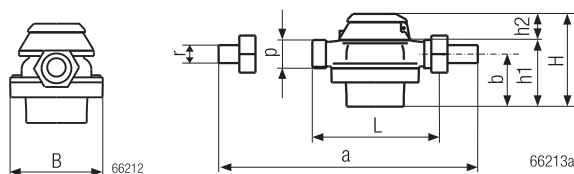

DN40: with threaded ends

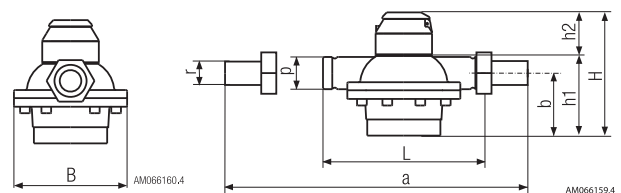

DN15, 20, 25: with flanges (DIN 2501/SN 21843)

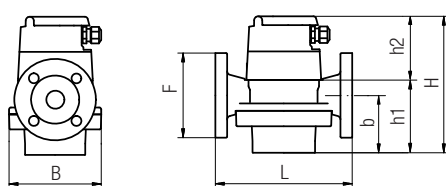

DN40, 50: with flanges (DIN 2501/SN 21843)

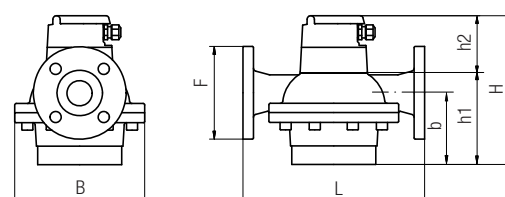

Nomial size	L	B	a	Ø F	b	h1	p	r
DN15	165	105	260	95	45	65	G 3/4"	G 1/2"
DN20	165	105	260	105	54	74	G 1"	G 3/4"
DN25	190	130	305	115	77	101	G 1 1/4"	G 1"
DN40	300	210	440	150	116	153	G 2"	G 1 1/2"
DN50	350	280	-	165	166	209	-	-

Diemnsions in mm

### Dimensions of transducer groups / measurement transducer

Sensor	DZ01 15 - 25						DZ01 40 - 50					
	130°C			180°C			130°C			180°C		
Max. temperature	130°C			180°C			130°C			180°C		
Pulsers	-	RV	IN	-	RV	IN	-	RV	IN	-	RV	IN
Dimensional drawing	-	2	3	6	5	4	8	4	7	5	4	8

### Dimensional drawings 1 - 8 from table above

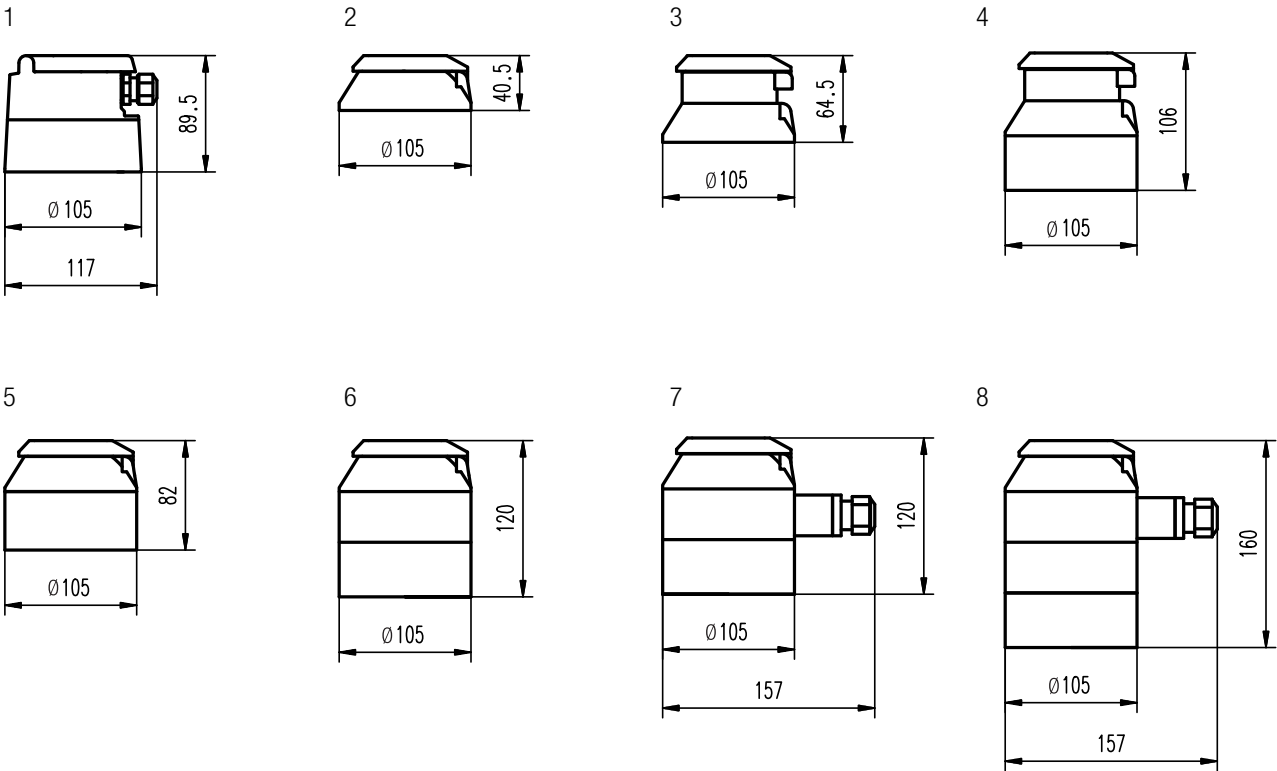

### Display / Roller counter

