



## ***Instruction Manual***

### ***DS10***

***Variable area flow meter with glass measuring tube***



PKP Prozessmesstechnik GmbH  
Borsigstraße 24  
D-65205 Wiesbaden-Nordenstadt  
Tel.: ++49-(0)6122-7055-0  
Fax: ++49-(0)6122-7055-50  
Email: [info@pkp.de](mailto:info@pkp.de) [www.pkp.de](http://www.pkp.de)

## **Table of Contents**

---

Safety Information.....	2
Functional Description.....	3
Installation.....	4
Dimensions:.....	5
Start-up.....	6
Limit Switches.....	7
Maintenance and Care.....	14

## **Safety Information**

---

### **General Instructions**

To ensure safe operation, the device should only be operated according to the specifications in the instruction manual. The requisite Health & Safety regulations for a given application must also be observed. This statement also applies to the use of accessories.

Every person who is commissioned with the initiation or operation of this device must have read and understood the operating instructions and in particular the safety instructions!

The work safety instructions in this manual as well as the safety, accident prevention and environmental protection regulations generally valid for the work area must be observed.

The liability of the manufacturer expires in the event of damage due to improper use, non-observance of this operating manual, use of insufficiently qualified personnel and unauthorized modification of the device.

### **Proper Usage**

Series DS10 float-type flow meters are designed to monitor continuous flow rates of liquids or gases which do not attack the device materials. All other usage is regarded as being improper and outside the scope of the device.

Unless indicated otherwise, the scales on these devices are based on air at 1.2 bar absolute pressure at 20°C or on water. Special applications in which shock-type loads are encountered (e.g. cyclic operation) should first be discussed with and examined by our engineering department.

The series DS10 flow meter devices should not be deployed as the sole agents to prevent dangerous conditions occurring in plant or machinery. Machinery and plant need to be designed in such a manner that faulty conditions and malfunctions do not arise that could pose a safety risk for operators.

## ***Dangerous substances***

For dangerous media such as e.g. Oxygen, Acetylene, flammable or toxic substances as well as refrigeration systems, compressors, etc. must comply with the relevant regulations beyond the general rules.

## ***Qualified Personnel***

The DS10 devices may only be installed by trained, qualified personnel who are able to mount the devices correctly. Qualified personnel are persons, who are familiar with assembling, installation, placing in service and operating these devices and who are suitably trained and qualified.

## ***Inward Monitoring***

Please check directly after delivery the device for any transport damages and deficiencies. Additional with reference to the accompanying delivery note the number of parts must be checked.

Claims for replacement or goods which relate to transport damage can only be considered valid if the delivery company is notified without delay.

## ***Functional Description***

---

The float-type flow meter must be installed in a vertical position. The flow must proceed in the direction from the low end to the high end of the scale.

This measuring device must be connected with fittings compatible with its design. When connecting the device, be sure that the pipes are run stress-free and aligned so that they are centered with the connection ports on the device. If necessary, support the pipes to prevent the transmission of vibrations to the device.

# Installation

---

## Installation in the pipeline:

### CAUTION!

When installing the device in the piping, the following points must be observed:

- The variable area flowmeter must be installed vertically (measuring principle). Flow direction from bottom to top.
- Before connecting, blow or flush out the pipes leading to the device.
- Piping for gas flow need to be dried before the device is installed.
- Use connectors suitable for the particular device version.
- Align the piping centrally with the connection bores on the measuring device so they are free of stresses.
- If necessary, the piping has to be supported to avoid the vibrations transmitted to the measuring device.
- Do not lay signal cables directly next to cables for the power supply.

## Panel mounting:

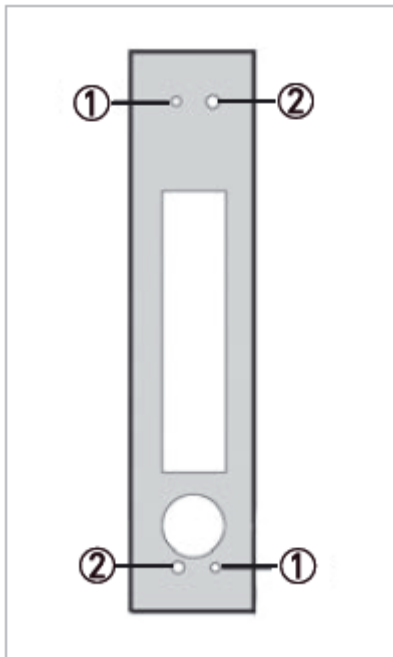

Prepare the panel cut-out as shown in the drawing.

For installation in the panel, slightly loosen the two screws 1) on the front panel of the measuring device.

The measuring device is inserted into the panel cutout from the front.

Align the device and fix it with the two screws 1) with 0.7 Nm.

Position of screws for panel mounting

- 1) Front side
- 2) Back side

**Panel cut-out and orifice plate:**

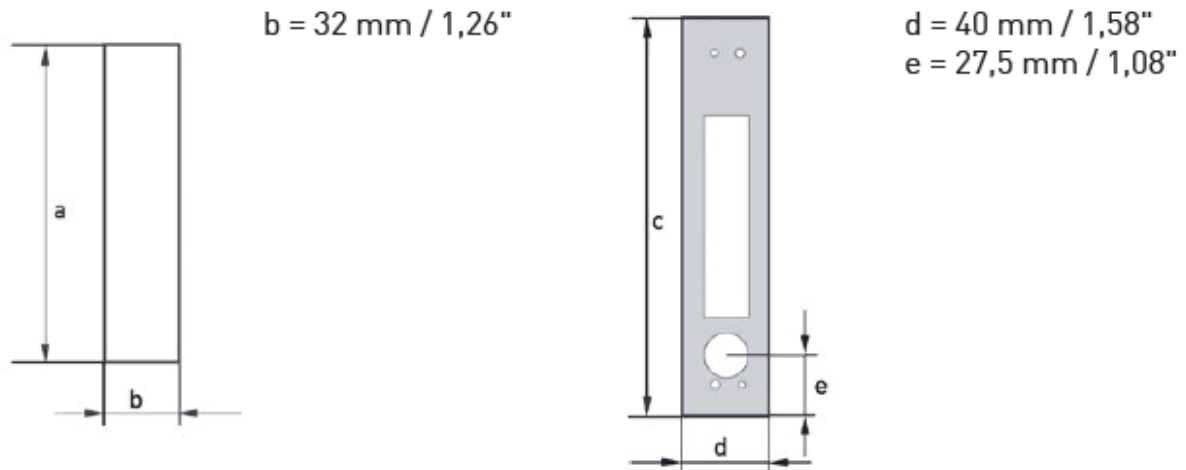

Version	a		c	
	[mm]	["]	[mm]	["]
DS10.1	128	5,04	145	5,71
DS10.2	163	6,42	180	7,09
DS10.3	213	8,39	230	9,06
DS10.4	363	14,3	380	15,0

**Dimensions:**

**Device versions:**

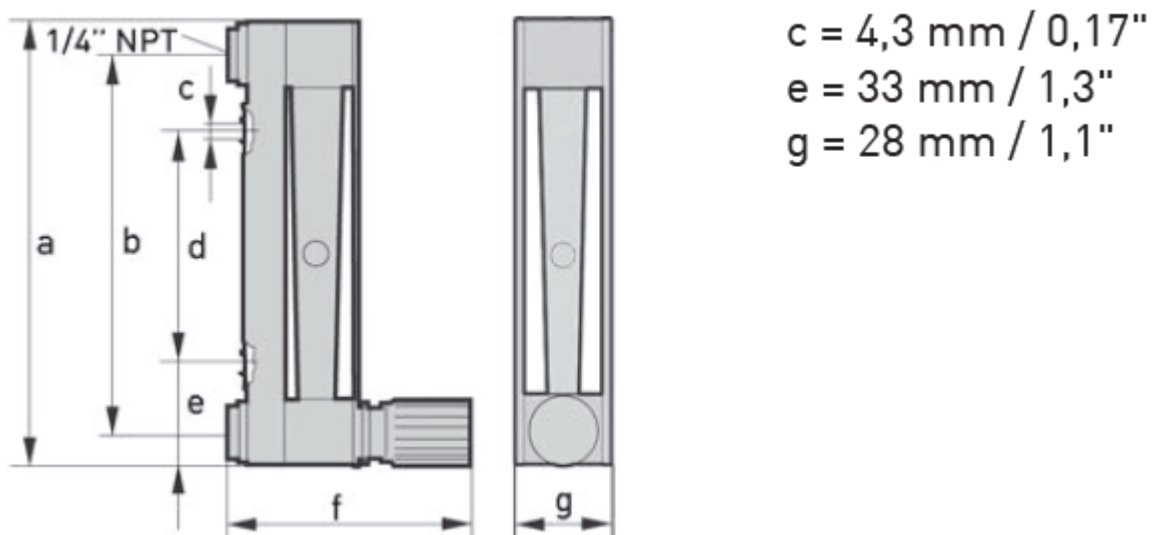

Version	a		b ± 0,25		d		f ca.	
	[mm]	[°]	[mm]	[°]	[mm]	[°]	[mm]	[°]
DS10.1	111	4,37	90	3,55	45	1,77	82	3,2
DS10.2	146	5,75	125	4,92	80	3,15	82	3,2
DS10.3	196	7,72	175	6,89	130	5,12	82	3,2
DS10.4	346	13,6	325	12,8	280	11,0	82	3,2

## Start-up

### CAUTION!

When starting up the device, the following points must be observed:

- Compare the actual operating pressure and the product temperature of the system with the specifications on the nameplate (PS and TS). These specifications may not be exceeded.
- Ensure the material compatibility.
- Close the needle valve at the flowmeter.
- Slowly open the shut-off valve.
- When measuring liquids ensure that the pipelines are carefully evacuated.
- When measuring gases, increase pressure slowly.
- Avoid float impact (e.g. caused by solenoid valves), as this is likely to damage the measuring unit or float.
- Open needle valve at the flowmeters and set the required flow rate.
- The top edge of the float, marks the reading line for flow values.

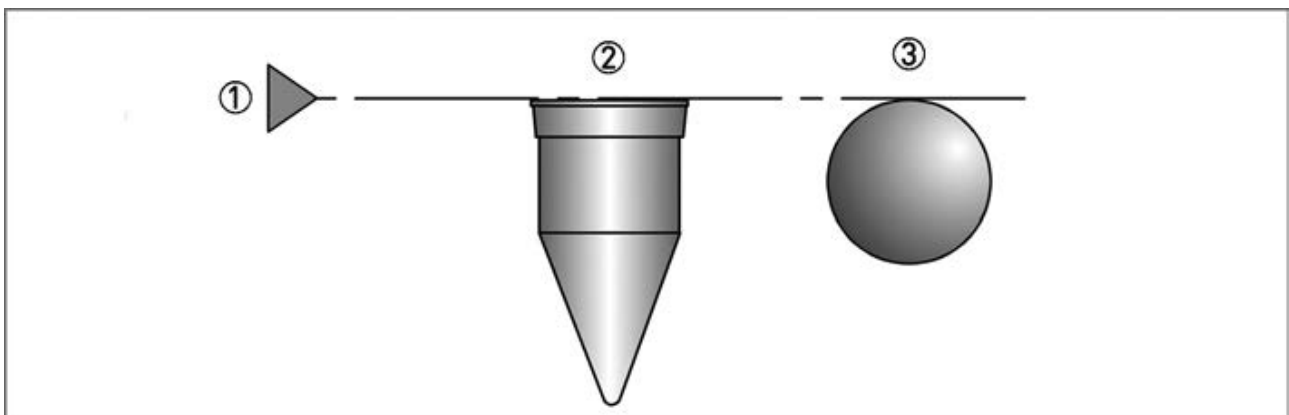

- 1) Reading line
- 2) Float shape "Alli"
- 3) Float shape "ball"

## Limit Switches

---

The flowmeters can be equipped with a maximum of two limit switches.  
The switching function of the limit switch can be designed as monostable or bistable.

Monostable function: Switching pulse as float passes through switching point,  
independent of direction of movement.

Bistable function: Stable changeover as float passes through switching point.

Example (bistable): Above limit: switching point "High"  
Below limit: switching point "Low"

For switching performance and electrical data refer to section "Technical data".

### **Electrical connections:**

Connection of limit switch - 2-wire NAMUR (standard):

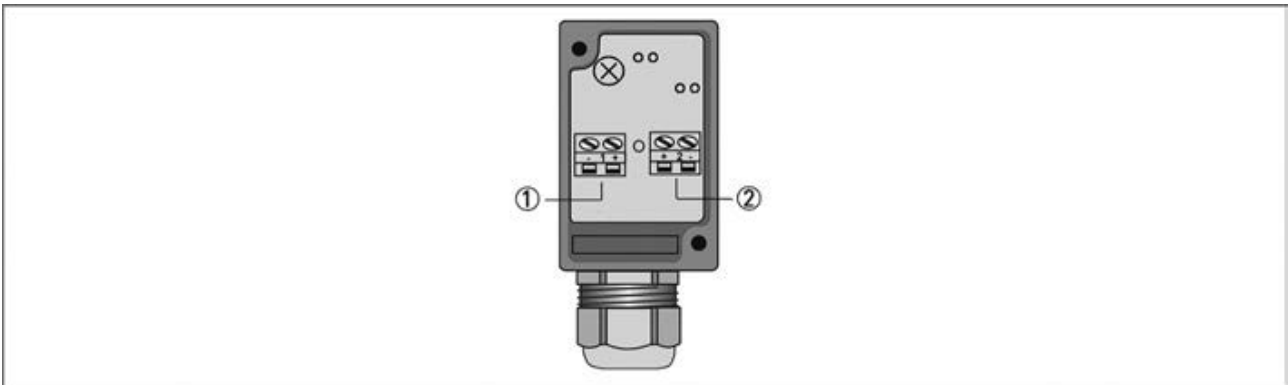

1 Lower limit switch to terminal 1

2 Upper limit switch to terminal 2

The connection box includes an EMC filter unit.

Connection of limit switch - 2-wire NAMUR, without connection box:

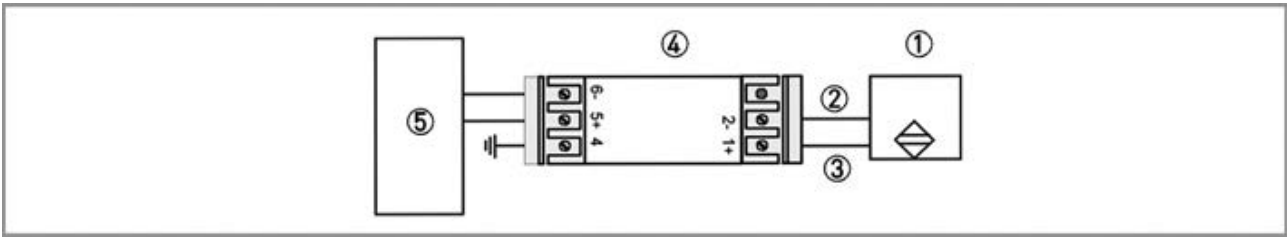

- 1 Limit switch (without connection box)
- 2 Blue cable -
- 3 Brown cable +
- 4 External EMC filter
- 5 Receiver device

When connecting to an EMC filter, the ground terminal must be connected to the back rail of the flowmeter.

Connection of limit switch - 3-wire (transistor):

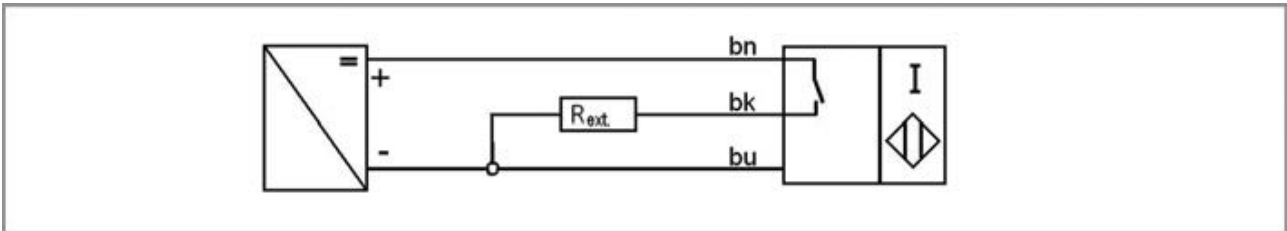

- bn - brown: supply voltage +
- bk - black: switch
- bu - blue: supply voltage -



## Settings of limit switches:

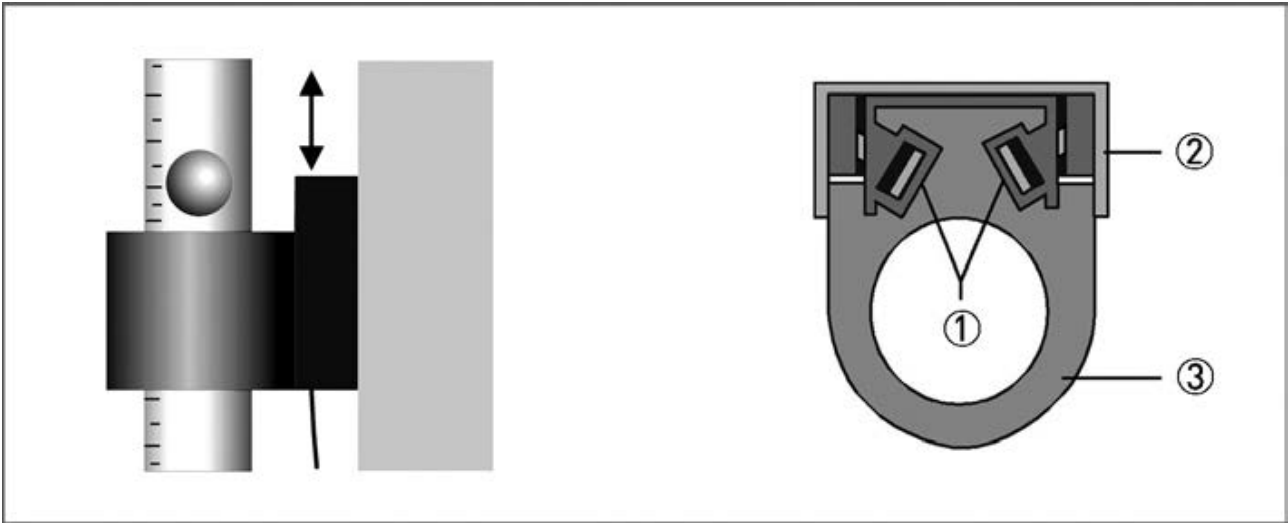

- 1 Clamping screw
- 2 Back rail
- 3 Limit switch

The following procedures are to be performed:

- Remove both clamping screws 1.
- Slide the limit switch over the measuring glass.
- Use the two clamping screws 1 to fasten the limit switch 3 to the back rail 2 of the measuring device.
- Re-install the protective cover following installation.

For installation after the fact, the measuring glass must be removed. Refer to chapter "Maintenance and care"

### CAUTION!

When setting the limit switch, be careful to lay the cable so that it does not get damaged. Avoid canting of the limit switch during installation: glass breakage

The connecting lead of the limit switch is guided through a hole in the base of the device and sealed.

Observe the following for bistable limit switches with external EMC filters in separate DIN rail housing:  
The EMC filter unit and the back rail of the meter must be galvanically connected and grounded.

An isolation switching amplifier with intrinsically safe circuit controls is necessary to operate the NAMUR limit switches.

### Minimum distance between two limit switches:

Where two limit switches are used in one device and also where meters with limit switches are in close proximity of each other, minimum distances must be maintained in order to avoid mutual influence of the switches.

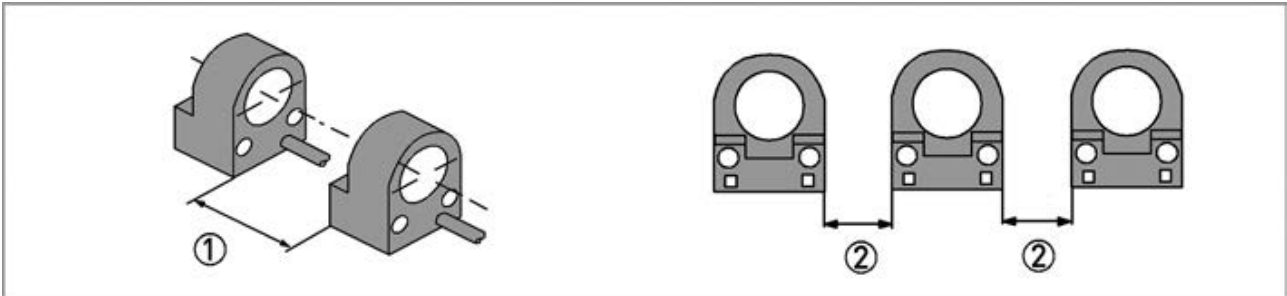

Minimum distance	2-wire		3-wire	
	[mm]	[inch]	[mm]	[inch]
①	16	0.63	45	1.77
②	6	0.24	30	1.18

### Switching performance of limit switches

#### 2-wire limit switch NAMUR, monostable

Float outside of the limit switch: signal  $\geq 3$  mA

Float inside of the limit switch (centre): signal  $\leq 1$  mA

#### 2-wire limit switch NAMUR, bistable

Independent of the float position and passage 1: signal  $\geq 3$  mA

Prerequisite: the float is outside the limit switch.

#### INFORMATION!

For the proper initialisation after power up, the bistable NAMUR limit switch should pass through each of 1 and 2 once.

#### 3-wire limit switch, transistor

Independent of the float position and passage 2: signal  $\leq 1$  V

Prerequisite: the float is outside the limit switch.

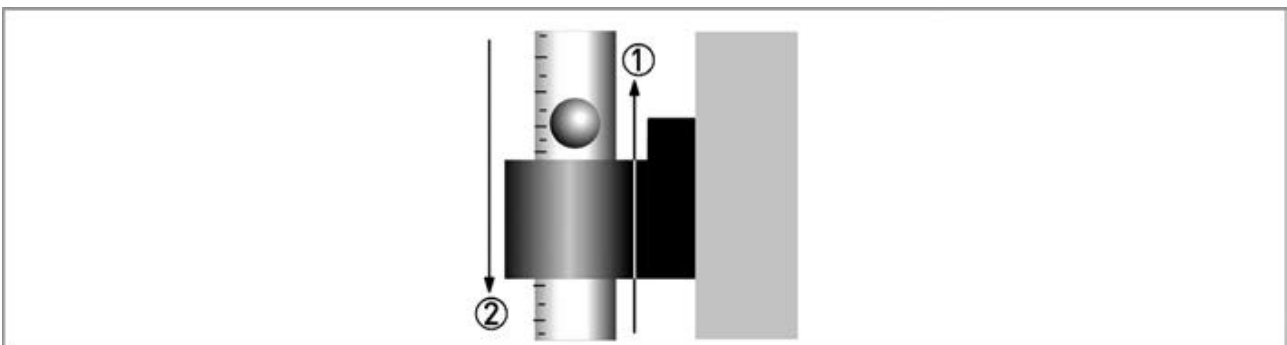

Switching performance

### **Reversed function of limit switch:**

The bistable limit switches can be changed from normally open switch to normally closed switch.

The pre-fabricated connection cable must be long enough to do this.

When installing and setting, make sure the cable is not damaged when laid.

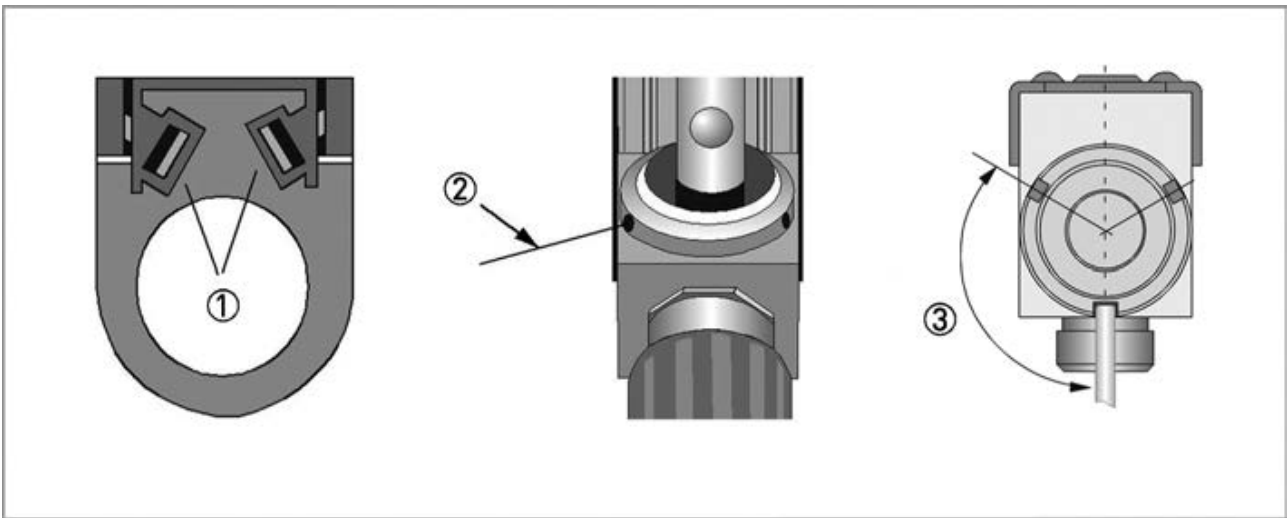

- Loosen terminal screw 1.
- Turn turnbuckle 2 counter-clockwise to loosen.
- Pull out the measuring glass along with the limit switch.
- Turn limit switch 180°.
- Install the measuring glass.
- Tighten turnbuckle 2 by hand.
- Use a 3 mm pin to tighten the turnbuckle by turning 4 to max. 5 times in 120° increments 3 in a clockwise direction.

### **CAUTION!**

To avoid breakage, the measuring glass must be positioned centrally between the gaskets.

Test the leak tightness by suitable measures prior to start-up.

### ***Grounding connection:***

The measuring unit is grounded on the back rail 1 (M4 thread). This connection only ensures electrostatic grounding of the device and does not meet the requirements for equipotential bonding.

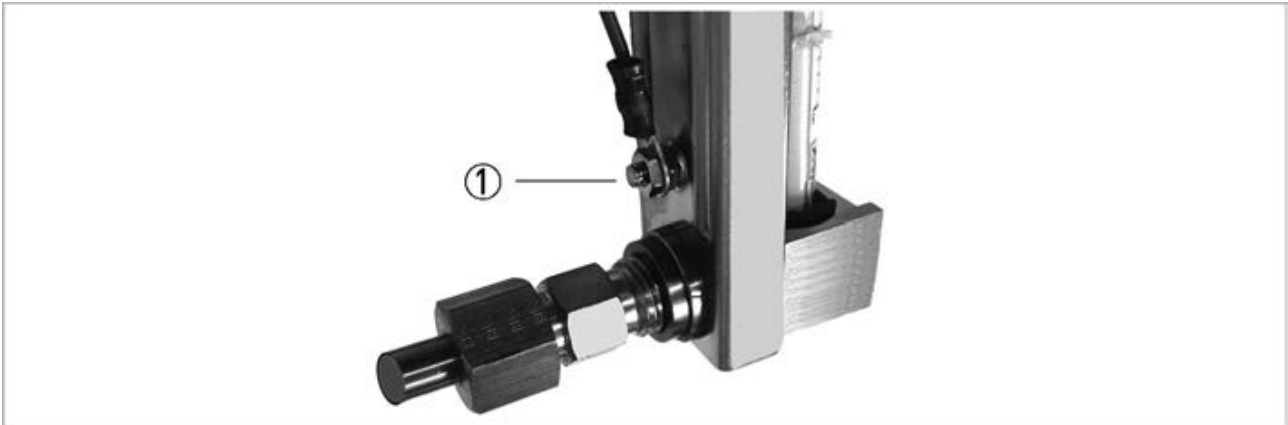

Position of the ground terminal

### **DANGER!**

The grounding wire may not transfer any interference voltage.  
Do not use this grounding cable to ground any other electrical devices.

### ***Ingress protection:***

The limit switches with connection housing meet all requirements of ingress protection IP65.

Therefore it is essential to observe the following points:

- Use only original gaskets. They must be clean and free of any damage. Defective gaskets must be replaced.
- The electrical cables used must be undamaged and must comply with regulations.
- The cables must be laid with a loop 3 upstream of the measuring device to prevent water from getting into the housing.
- The cable feedthroughs 2 must be tightened.
- Close the unused cable feedthroughs with blanking plugs 1



Ingress protection

### **DANGER!**

After all servicing and maintenance work on the measuring device, the specified protection class must be ensured again.

### ***Technical data of limit switches:***

Terminal connection	Connection box M16 x 1.5				
Clamping range	3...7 mm / 0.12...0.28"				
Limit switches	I7R2010-NL RC10-14-N3	I7R2015-NL RC15-14-N3	I7R2010-N RC10-14-N0	I7R2015-N RC15-14-N0	RB15-14-E2
Ring diameter	10 mm / 0.4"	15 mm / 0.6"	10 mm / 0.4"	15 mm / 0.6"	15 mm / 0.6"
Switching function	bistable	bistable	monostable	monostable	bistable
NAMUR	yes	yes	yes	yes	no
SIL2-compliant according to IEC 61508	yes	yes	no	no	no
Connection technology	2-wire	2-wire	2-wire	2-wire	3-wire
Nominal voltage $U_0$	8 VDC	8 VDC	8 VDC	8 VDC	-
Current consumption	1 mA passage ↓ ①		3 mA - float outside		-
Current consumption	3 mA passage ↑ ①		1 mA - float inside of the limit switch		-
Operating voltage $U_{ext.}$	-				10...30 VDC
Operating current I	-				0...100 mA
No-load current I	-				20 mA
Output $U_a$ - passage ↓	-				≤1 VDC ①
Output $U_a$ - passage ↑	-				≥ $U_b$ - 3 VDC ①

1) For devices with the valve at the top in the output and devices with flow regulators for variable outlet pressure, the function is inverted!

### **INFORMATION!**

The limit switches with ring diameters of 15 mm / 0.6" as max. contact can only be used up to 60 l/h / 15.8 GPH water or 2400 l/h / 89.3 SCFH air (outer diameter of the measuring glass).

## ***Maintenance and Care***

---

Due to the small number of moving parts, these devices require minimal maintenance. Nevertheless, regular performance tests and maintenance will not only increase the service life and functional safety of the device but also those of the entire installation.

The frequency of maintenance depends on the following:

- The contamination of the medium
- Ambient conditions (e.g. vibrations)
- 

When performing maintenance, be sure to check for the following:

- Proper function of the switching contact (on devices with limit value signal sensors)
- Leakage at the device
- Free movement of the float

The user is responsible for setting suitable maintenance intervals for the specific application.

### **Maintenance Notes:**

- The free movement of the float can be checked by changing the flow rate and observing the float.
- In most cases, cleaning the device will only require rinsing it with clean liquid. In stubborn cases (e.g. lime deposits), standard, commercially available cleaners can be used as long as their ingredients will not attack the materials used in the device.

### **Replacing the Measuring Tube:**

Caution: To avoid glass breakage, the measuring tube must be installed centered between the seals.

1. Close the valves upstream and downstream of the device to prevent escape of the medium being measured.
2. Close the needle valve at the device.
3. Slide the Plexiglas protective cover upward and then remove it toward the front.
4. To release the measuring tube, turn the retainer in the base of the device counter-clockwise. The tube can now be removed.

To reinstall the tube, follow the above instructions in reverse order.

# DS10

## Variable Area Flowmeter with Glass Measuring Tube

- for low viscous liquids and gases
- fittings of brass or stainless steel
- with integrated needle valve
- limit switch optionally
- accuracy class 4, 2,5 or 1,0
- max. pressure 10 bar, max. temperature 100 °C
- measuring ranges: 0,04...160 l/h water  
0,5...5000 NI/h air



### Description:

The flowmeters DS10 operate according to the proven variable area principle. The flowing media moves a float upwards against gravity in a conical measuring tube. The height of the float indicates the flow rate and may be read off a burnt-in scale on the measuring tube.

Optional inductive contacts, which are mounted on the measuring tube, may be used for flow rate limit detection. All meters are equipped with an integrated needle valve for exactly regulating the flow rate.

### Typical applications:

Variable area flowmeters model DS10 are mainly used for measuring and monitoring the flow rate of low- viscous liquid and gaseous media.

Scales for water or air at standard operating conditions have already been defined. For other media or different process conditions special scales are available.

## Models:

- DS10.1:** miniature version, installation high 111 mm  
accuracy class 4
- DS10.2:** standard version, installation high 146 mm  
accuracy class 2,5
- DS10.3:** maxi version, installation high 196 mm  
accuracy class 2,5
- DS10.4:** precision version, installation high 346 mm  
accuracy class 1,0

## Measuring Ranges:

The measuring ranges given below serve as orientation. Please indicate medium, pressure and temperature, we will calculate an individual scale for you.

Measuring range- No	Measuring range [NI/h] air, 20°C, 1,2 bar abs.	Contact- version	Models			
			DS10.1	DS10.2	DS10.3	DS10.4
01	0,5...5	A	x	x	-	-
02	0,8...8	A	x	x	-	-
03	1,6...16	A	x	x	x	x
04	4...40	A	x	x	x	x
05	6...60	A	x	x	x	x
06	10...100	B	x	x	x	x
07	25...250	B	x	x	x	x
08	50...500	B	x	x	x	x
09	80...800	B	x	x	x	x
09A	120...1200	B	x	-	-	x
10	100...1000	B	-	x	-	x
11	180...1800	B	-	x	-	x
12	240...2400	B	-	x	-	x
13	300...3000	B (min)	-	x	-	x
14A	400...4000	B (min)	-	x	-	-
15A	500...5000	B (min)	-	x	-	-
<b>[l/h] water</b>						
40A	0,04...0,4	-	-	-	-	x
41A	0,063...0,63	-	-	-	-	x
42A	0,1...1	-	-	-	-	x
43A	0,16...1,6	A	-	-	-	x
16	0,25...2,5	A	x	x	-	x
17	0,5...5	B	x	x	x	x
18	1,2...12	B	x	x	x	x
19	2,5...25	B	x	x	x	x
20	4...40	B	x	x	x	x
21	6...60	B	x	x	x	x
22	10...100	B (min)	x	x	x	x
23	12...120	B (min)	x	x	-	-
24	16...160	B (min)	x	x	-	-

x = available - = not available

**Contacts:** The contact version is determined by the measuring range.

(min) = Contact available for minimum monitoring only.

## Dimensions:

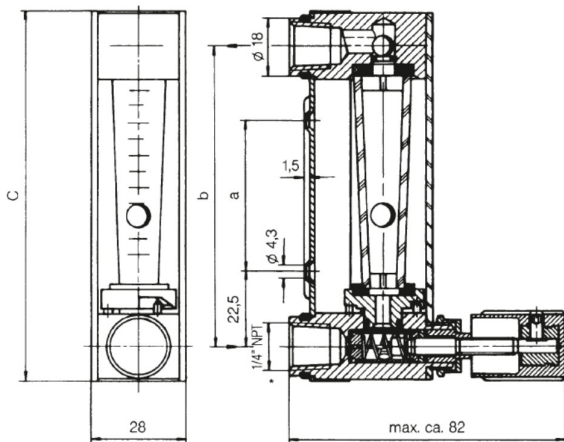

The upper edge of the float is the reading edge.

Models	a [mm]	b [mm]	c [mm]
DS10.1	45	90	111
DS10.2	80	125	146
DS10.3	130	175	196
DS10.4	280	325	346

## Order Code:

Order number: **DS10. 2. 1. 1. 1. 06. 1. 1. 0**

**Variable area flowmeter  
with glass measuring tube**

### Models:

- 1 = miniature version  
2 = standard version  
3 = maxi version  
4 = precision version

### Process connection:

- 1 = G 1/4 female on back  
2 = 1/4" NPT on back

### Material:

- 1 = brass  
2 = stainless steel

### Gasket:

- 1 = FKM (standard)  
2 = PTFE / FFKM  
3 = EPDM

### Measuring ranges:

- 01...24 = according to table  
99 = special ranges

### Valve:

- 0 = without  
1 = valve at inlet (standard)  
2 = valve at outlet

### Limit switches:

- 0 = without  
1 = 1 contact (contact model A)  
2 = 2 contacts (contact model A)  
3 = 1 contact (contact model B)  
4 = 2 contacts (contact model B)

### Options (multiple answers possible):

- 0 = without  
1 = panel mounting kit  
2 = cable connector housing for devices with contact

Special connections like hose connectors, SWAGELOK, ERMETO or others on request.

To operate the limit switches, switch amplifiers of type P+F are required. See data sheet **P+F**.

## Technical Data:

**Max. pressure:** 10 bar

**Max. medium temperature:** 100 °C (65 °C with contact)

### Materials:

- fitting and valve:** brass or stainless steel,  
**float:** stainless steel  
**gaskets:** FKM / EPDM or PTFE / FFKM,  
**measuring tube:** borosilicate glass

### Accuracy:

- DS10.1: class 4  
DS10.2: class 2,5  
DS10.3: class 2,5  
DS10.4: class 1,0

### Switch contacts:

- acc. to NAMUR (bistable)  
1 mA passage from top to bottom  
3 mA passage from bottom to top  
(monostabile or 3-wire contacts on request)