



Instruction Manual

DR20B

Paddle Wheel Flow Transmitter



PKP Prozessmesstechnik GmbH
Borsigstraße 24
D-65205 Wiesbaden-Nordenstadt
Tel.: ++49-(0)6122-7055-0
Fax: ++49-(0)6122-7055-50
Email: info@pkp.de www.pkp.de

Safety Information

General Instructions

To ensure safe operation, the device should only be operated according to the specifications in the instruction manual. The requisite Health & Safety regulations for a given application must also be observed. This statement also applies to the use of accessories. Every person who is commissioned with the initiation or operation of this device must have read and understood the operating instructions and in particular the safety instructions!

The liability of the manufacturer expires in the event of damage due to improper use, non-observance of this operating manual, use of insufficiently qualified personnel and unauthorized modification of the device.

Proper Usage

Model DR20B devices are designed to measure and monitor the flow of low-viscosity liquids, which do not attack the device materials. All other usage is regarded as being improper and outside the scope of the device. Any applications in which shock loads (e.g. cyclic mode) occur, should be cleared first with PKP.

The flow sensor can be installed in any position. If it is installed in vertical pipes, the flow direction from bottom to top is to be preferred. A free outlet must be avoided. The arrow on the flow sensor indicates the only possible flow direction. The formation of gas bubbles in the medium and cavitation must be prevented by suitable measures. The units must not be blown out with compressed air, operation without liquid would damage the bearings.

The series DR20B devices should not be deployed as the sole agents to prevent dangerous conditions occurring in plant or machinery. Machinery and plant need to be designed so that faulty conditions do not arise that could pose a safety risk for operators.

Dangerous substances

For dangerous media such as e.g. Oxygen, Acetylene, flammable or toxic substances as well as refrigeration systems, compressors, etc. must comply with the relevant regulations beyond the general rules.

Qualified Personnel

DR20B devices may only be installed by trained, qualified personnel who are able to mount the devices correctly. Qualified personnel are persons, who are familiar with assembling, installation, placing in service and operating these devices and who are suitably trained and qualified.

Inward Monitoring

Please check directly after delivery the device for any transport damages and deficiencies. Additional with reference to the accompanying delivery note the number of parts must be checked.

Claims for replacement or goods which relate to transport damage can only be considered valid if the delivery company is notified without delay.

Mounting

The device has to be mounted solely by the process connections using a suitable gasket material. Before mounting them make sure that there are no foreign particles like rests of the packaging in the bore. Tighten carefully the adapters to the pipe.

Inlet and Outlet pipe

To achieve best performance and accuracy, a straight inlet pipe of at least 10 x DN must be installed before the flowmeter. Behind the device, an outlet pipe of at least 5 x DN is recommended. The inner diameter of inlet and outlet pipe has to be the same as the of the flowmeter. After inlet and outlet, adaptors to fit other diameters are allowed.

Measuring ranges / K-Factors / Frequency

DN	R	Measuring range ¹⁾ [l/min]	K-Factor [Pulses/l]	Frequency ²⁾ [Hz]
15	1/2"	2,5...50	170,4...181	142...151
20	3/4"	5,5...92	92,6...99,5	142...151
25	1"	8...145	58,8...62,5	142...151
32	1 1/4"	14...240	35,5...37,8	142...151
40	1 1/2"	22...375	22,7...24,2	142...151
50	2"	35...580	14,7...15,6	142...151
A		0,3...5 m/s	/	142...151

Electrical Connection

Please note:

We recommend to use only shielded cables.

Before carrying out the electrical installation, make sure that the supply voltage corresponds to the data provided!

Switch off any power supply before the electrical installation.

The devices are equipped with an integrated electronic unit and can be used out of the box.

Pin Assignment

The devices are equipped with a weld-on cable:

For devices with analogue output:

connection	assignment
White	⊕ power supply (+Ub, 24 VDC)
Brown	⊖ power supply (-Ub, 24 VDC)
Green	⊖ Signal output (- Iout)
Yellow	⊕ Signal output (+ Iout)

The analogue output is factory adjusted, corresponding flow rate see attached label. It is not possible to change this setting.

For devices with pulse output:

connection	assignment
White	⊕ power supply (+Ub, 24 VDC)
Brown	⊖ power supply (-Ub, 24 VDC)
Green	⊖ Signal output (- Iout)
Yellow	NPN open collector

Recommended pull-up resistor 2200 Ohm.

DR20B

Paddle Wheel Flow Transmitter

- for low viscosity liquids
- large measuring range
- high quality bearings
- high accuracy
- essentially temperature-independent
- linear output signal
- small mounting dimensions
- measuring ranges: 2,5...50 l/min up to 35...580 l/min
- max. temperature: 100 °C, max. pressure: 25 bar



Description:

The flow transmitter model series DR20B work acc. to the paddle wheel principle. The medium flows unilaterally against the paddle wheel and puts it into rotation. This leads to a low response sensitivity combined with a high turndown ratio up to 1:20. The devices are in the version with a T-fitting for nominal sizes of DN 15 until DN 50 available. Therefore measuring ranges of initially 2,5 l/min up to 580 l/min can be covered.

In principle a weld on version can be used for many different pipe diameters. The analogue output is proportional to the flow rate and covers the range 0,3 until 5 m/s.

Typical applications:

The paddle wheel flowmeter of the type series DR20B can be used for flow measuring of all low viscous liquids that are not aggressive to the used materials.

Because of the high quality bearings the devices work very reliably.

Technical Data:

Connection:	weld on nozzle (Type A) or T-fitting with R-thread
Sensor:	Hall-Sensor / magnet
Temperature range:	
Sensor:	-40...+100 °C (130°C on request)
Electronic:	-10... +60 °C
Max. pressure:	
T-fitting version:	10 bar
weld on version:	25 bar
Accuracy:	± 2% of FS

Electrical Data:

Power supply:	12...26 V _{DC} (shunt resistance < 400 Ω) 15...26 V _{DC} (400 Ω > shunt resistance < 500 Ω)
Analogue output:	analogue output 4...20 mA (3-wire source)
Pulse output:	NPN (142...151 Hz), not linearised PNP, Push Pull
Power consumption:	50 mA max.
Electr. connection:	cable 3,0 m (4 x 0,14 LYCY)
Protecton class:	IP65

Materials:

Housing:	stainless steel 1.4571
Paddle wheel:	POM
Bearings:	Sapphire / ruby
Shaft:	Hard ferrite
O-ring:	FKM

Measuring ranges:

DN	R	Measuring range ¹⁾ [l/min]	K-Factor [Pulses/l]	Frequency ²⁾ [Hz]
15	1/2"	2,5...50	170,4...181	142...151
20	3/4"	5,5...92	92,6...99,5	142...151
25	1"	8...145	58,8...62,5	142...151
32	1 1/4"	14...240	35,5...37,8	142...151
40	1 1/2"	22...375	22,7...24,2	142...151
50	2"	35...580	14,7...15,6	142...151
A		0,3...5 m/s	/	142...151

¹⁾ The output signal can be factory-set to a value other than the measuring range end value. Please specify when ordering.

²⁾ The exact frequency at maximum flow or at a maximum speed of 5 m/s is measured individually and indicated on the type plate.

Order Code:

Order number: DR20B. 15. Axxx. 0

Paddle wheel flow transmitter

Connection and measuring range:

15	= T-fitting, 1/2", 2,5...50 l/min
20	= T-fitting, 3/4", 5,5...92 l/min
25	= T-fitting, 1", 8...145 l/min
32	= T-fitting, 1 1/4", 14...240 l/min
40	= T-fitting, 1 1/2", 22...375 l/min
50	= T-fitting, 2", 35...580 l/min
A	= weld on version for flow rates of 0,3...5 m/s

Output:

Axxx	= 4...20 mA, xxx = adjustment 20 mA, electronic plug
W	= Pulse output NPN, cube plug
K	= Pulse output NPN, cable output
S	= Pulse output PNP, Push Pull, electronic plug

Options:

0	= without
1	= please specify in plain text

In the enquiry or order please indicate the following informations:

- Media viscosity, if different from water
- Pressure and temperature
- Mounting position and direction of flow

Dimensions:

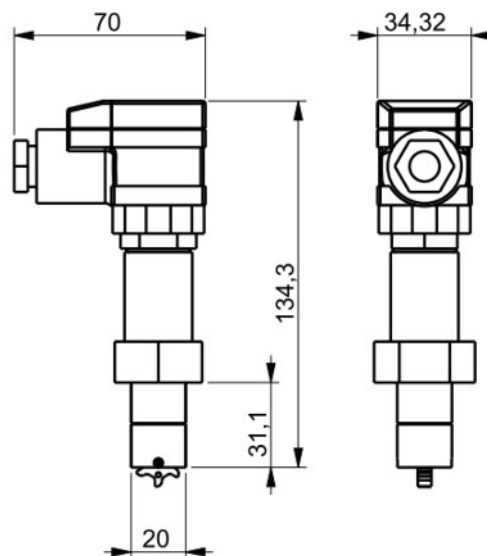

Nominal size	Length A [mm]	Length B [mm]
DN 15	80	43
DN 20	55	43
DN 25	58	51
DN 32	65	62
DN 40	67	68
DN 50	78	81