



Instruction Manual

DG10 / DG11

***Sight Flow Indicator with Threaded Connection
or Flanged Connection***



PKP Prozessmesstechnik GmbH
Borsigstraße 24
D-65205 Wiesbaden-Nordenstadt
Tel.: ++49-(0)6122-7055-0
Fax: ++49-(0)6122-7055-50
Email: info@pkp.de

Table of Contents

Safety Information.....	2
Functional Description.....	3
Risk and Safety References.....	3
Storage and Transport.....	4
Intended use and Material Selection.....	4
Installation.....	5
Commissioning.....	6
Maintenance and Service.....	6
Replacement of Glass Plates.....	7

Safety Information

General Instructions

To ensure safe operation, the device should only be operated according to the specifications in the instruction manual. The requisite Health & Safety regulations for a given application must also be observed. This statement also applies to the use of accessories. Every person who is commissioned with the initiation or operation of this device must have read and understood the operating instructions and in particular the safety instructions!

The liability of the manufacturer expires in the event of damage due to improper use, non-observance of this operating manual, use of insufficiently qualified personnel and unauthorized modification of the device.

Proper Usage

The sight flow indicators DG10 / DG11 are designed to monitor continuous flow rates of liquids or gases which do not attack the device materials. All other usage is regarded as being improper and outside the scope of the device.

In particular, applications in which shock loads occur (for example, pulsed operation) should be discussed and checked in advance with our technical staff.

The series DG10 / DG11 flow meter devices should not be deployed as the sole agents to prevent dangerous conditions occurring in plant or machinery. Machinery and plant need to be designed in such a manner that faulty conditions and malfunctions do not arise that could pose a safety risk for operators.

Dangerous substances

For dangerous media such as e.g. Oxygen, Acetylene, flammable or toxic substances as well as refrigeration systems, compressors, etc. must comply with the relevant regulations beyond the general rules.

Qualified Personnel

The DG10 / DG11 devices may only be installed by trained, qualified personnel who are able to mount the devices correctly. Qualified personnel are persons, who are familiar with assembling, installation, placing in service and operating these devices and who are suitably trained and qualified.

Inward Monitoring

Please check directly after delivery the device for any transport damages and deficiencies. Additional with reference to the accompanying delivery note the number of parts must be checked.

Claims for replacement or goods which relate to transport damage can only be considered valid if the delivery company is notified without delay.

Functional Description

The sight flow indicators DG10 / DG11 are built into piping (flanged, screwed or welded). They serve to make possible the visual inspection of flowing through medium qualitatively and quantitatively for the operator. For this the sight flow indicator is provided with 2 opposite glass plates.

For design, dimensions and materials see the corresponding data sheets. Before leaving our works, all PKP sight flow indicators are examined acc. to DIN 3230 (or corresponding special arrangements) with 1.5 times nominal pressure for strength. Additional to that, we also make a leakage test by loading a submerged sight glass with compressed air with a pressure of 2 to 6 bar.

Risk and Safety References

Very careful dealing with glass plates and sight flow indicators is required:

- It must be guaranteed that all work on or with glass plates and sight flow indicators is done by trained personnel.
- The valid safety regulations, especially for piping under pressure and temperature, must be considered.
- Installation and maintenance must be done exclusively in pressure less and cooled off condition. Shut off reliable supply pipes, in case of back pressure also waste pipes.
- Please use only original spare parts.

Attention:

During operation, the sight flow indicators are under pressure and mostly hot! Maintenance during operation means danger of serious burning and cauterization by contact with the process fluid.

Storage and Transport

The sight flow indicators are to be transported and storage in professionally packing. They must be kept dry and protected against dirt. Especially the glass plates must be protected against impact and scratching.

Storage: From -10 °C to +40 °C in a clean and dry room.
Period of storage: Max. 3 years. After that time the seals must be checked and possibly replaced.
Lacquer finish: Cast iron and cast steel indicators are provided with a basic colour which is to protect against corrosion only during transport and storage. Therefore take care not to damage the colour. Condensation must be absolutely avoided.

Protective caps should be removed only shortly before installation.

Intended use and Material Selection

Operational area and material selection are subject to the responsibility of the operator and/or designer of the system.

Body material and seals:

These must be selected carefully with consideration of the flowing through medium as well as the operating conditions (pressure and temperature).

Glass plates:

Soda lime glass according to DIN 8902: max. 150 °C

Borosilicate glass according to DIN 7080: max. 280 °C

Especially for desalinated condensate or steam mixture and pH values starting from 8 an additional protection by mica sheets is recommended.

Pressure – Temperature – Operational Limits

Operating temperature up to:	120 °C	150 °C	200 °C	250 °C	280 °C
PN 16 / ANSI 150 lbs	16	15	14	13	11
PN 25	25	23	22	20	17
PN 40 / ANSI 300 lbs	40	37	35	32	28

Attention:

The lowest value in the combination “body – seals – glass plates” decides the maximally permissible limit for temperature and pressure! If there is any doubt, please contact PKP.

Installation

- Any installation position is possible (except design with flap: installation horizontal or vertical with flow below upwards).
- The casted or hit indication arrow for the flow direction is to be considered absolutely.
- Before installation take care that piping and indicators are free of dirt.
- Transmission of piping tensions on the sight flow indicators due to the installation process is to be avoided.
- Remove protection caps only shortly before installation to avoid damages of the contact faces.

Flange connection:

- Piping flanges have to be concentrically and parallel. Size of the flange and type of contact faces must fit the sight flow indicators.
- Distance of piping flanges = length of sight flow indicators plus twice seals strength.
- The connection screws must be tightened crosswise, gradually and steadily.
- The torques depends mainly to the used sealing material.

Thread connection:

- The thread of the sight flow indicator must fit the external thread of the piping in thread type, size and lead.
- When screwing in, the indicators must be kept absolutely directly at the screwed end with a suitable fork wrench or pliers.
- Don't hold at the end of the sight glass covers on no account, because glass break is to be feared.

Welded sight glass fittings:

- Before welding, the welded ends of the sight glass indicators and piping are to be cleaned thoroughly and checked whether they fit to each other (diamater, welding chamfer etc.).
- Welding is to be done only by trained technical personnel with suitable welding methods and welding additives acc. to valid rules of technology. E-welding is to be preferred.

Attention:

Glass plates and seals should be taken off during the welding procedure or should be covered inside and outside to protect them against welding gases and welding splashes.

Commissioning

Before first starting up the torques of the fixing screws of the two cover flanges are to be checked and corrected (especially after a longer intermediate storage!). The torques and procedure described in “replacement of glass plates” are to be considered!

After the first load with pressure and temperature you can count on a certain “settling” of the seals. Therefore the fixing screws of the covers are to be checked once more in cold and pressureless condition and possibly corrected.

Maintenance and Service

PKP sight flow indicators don't required a special maintenance.

If the glass plates should be dirty at the outside, they can be cleaned carefully. The glass surface may not be scratched under any circumstances (stability loss!). Commercial cleaning agents, especially glass cleaning agents, may be used. Use only clean and soft cloth!

Inside dirtying of the glass plates may also be cleaned as described before. If the dirt sticks so tight on the glass plates that cleaning as described above is no more successful, the glass plates have to be replaced. Replacement is also necessary if they are corroded by flow or aggressive medium and show an erosive surface (stability loss!).

When assembling the cleaned or replaced glass plates, new seals in suitable quality are to be used under all circumstances. See “replacement of glass plates” and “safety references”.

General references:

Although highly resistant, sight glass plates acc. to DIN 8902 and DIN 7080 are wearing parts with limited lifespan. This depends very much on the specific demand on operation. With rising temperature and rising pH value of the medium the glass erosion increases exponentially. High glass erosion can have a very negative effect on the operational safety. Therefore both glass plates and seals are to be replaced, if there is a recognizable glass erosion.

It is advisable to document the specific period of use of the glass plates, so that experience values of the lifespan in concrete case of operation can be collected. That way the punctual and routine replacement of the glass plates can be planned very well.

Replacement of Glass Plates

Attention:

All work on glass plates has to be done by trained personnel in compliance with safety instructions! - Glass plates require very careful treatment!

Disassembly:

- Remove the fixing screws of the cover flanges in several steps and crosswise. Remove the cover flanges.
- Remove the glass plates as well as the inside and outside seals.
- Clean the sealing surface at the body as well as the bearing surface in the cover flange carefully from sealing remainders and check them on damages (scores, wash out, impact spots etc.). Both surfaces must be absolutely clean, flat and without damages!

New assembly:

- Lay down the inside seal (at body side) and the new glass plate of correct size and quality exactly centrally. The seal may not project in the view diameter d_1 . The glass plate has to show a constant gap of approx. 1 to 1,5 mm at the complete outside diameter. A contact between glass plate and metal body may not be under any circumstances! This would lead to damage and total breakdown of the glass plate due to different extension coefficients.
- Lay down the outside seal (at cover side) and cover flange exactly centrally on the glass plate. Between glass plate and cover flange the gap of approx. 1 to 1,5 mm mentioned above must also be absolutely guaranteed.
- Screw in the fixing screws carefully and tightens them gently by hand. While doing so, all seals and the cover flange may not be shifted! Threads and bearing surfaces of the fixing screws have to be lubricated with temperature resistant thread paste (e.g. OKS ANTI-Seize-Paste) before screwing in to avoid seizing of materials and guarantee defined friction values.
- Now tighten all screws in several little steps and crosswise (acc. to the opposite picture) with a torque wrench to the torques mentioned in the below chart. All screws must show exactly the same torque to avoid glass tensions.

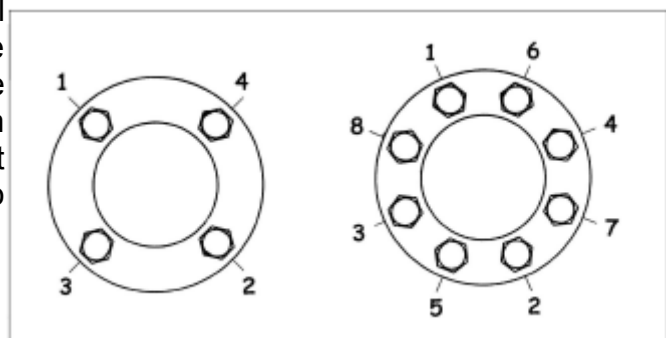

Torques of cover flange screws:

Torques of cover flange screws in [Nm] for lubricated screws and for standard seals made of graphite with stainless steel reinforcement:

Glass Ø d ₂ in mm	View Ø d ₁ in mm	4 x M 8	4 x M 10	4 x M 12	4 x M 14	4 x M 16	8 x M 16
45	32	10	12	--	--	--	--
63	48	12	20	23	--	--	--
80	65	--	23	30	--	40	--
100	80	--	--	42	--	70	35
125	100	--	--	--	65	--	50
150	125	--	--	--	--	100	60
175	150	--	--	--	--	--	80
200	175	--	--	--	--	--	90

Correction values for other sealing materials:

PTFE:	above mentioned values x 0,5
Aramide fibre:	above mentioned values x 0,7
Viton, Silicone, EPDM etc.:	above mentioned values x 0,6
Other materials:	on request

- Second opposite glass plate side is to be disassembled and assembled again as described above.
- Finally the sight glass fitting is to be checked for thickness (e.g. with compressed air / gas of approx. 2 bar under water).
- After the first restarting the cover flange screws must be controlled absolutely in cold and pressureless condition to meet the "settling" of new seals.

DG10

Sight Flow Indicator with Threaded Connection

- applicable for liquids and gases
- standard models with fully clear bore or drip tube, flap or rotor optionally available
- materials: cast iron, cast steel or stainless steel
- for pipe sizes from 1/4" to 2"
- for media-temperature up to 300 °F / 150 °C, higher ratings up to 536 °F/ 280 °C optionally available
- pressure rating: 232 psi/ PN1 6, 363 psi/ PN 25, 580 psi/ PN 40, higher pressure ranges optionally available



Description:

DG10 sight glasses are used to visually monitor the flow of liquids in pipe systems.

Depending on the type of liquid and flow volume, these devices are used with a fully clear bore or with a flap or rotor (for transparent liquids).

DG10 sight glasses permit reliable monitoring of the function and performance of single devices or entire systems.

Models:

Typical Applications:

Because they are available in a variety of materials and designs, DG10 sight glasses can be used in almost any kind of pipe system.

- DG10.S:** standard model with fully clear bore, sizes G 1 1/4 and above with drip tube (can be installed in any position)
- DG10.K:** with flap (can only be installed horizontally or for upward vertical flows)
- DG10.RK:** with rotor made of POM (Tmax. 248 °F / 120 °C, can be installed in any position, but axis horizontal), for liquids only
- DG10.RP:** with rotor made of PTFE (Tmax. 500 °F/ 260 °C, can be installed in any position, but axis horizontal), for liquids only

Consider flow direction!

Housing Materials (wetted parts):

- DG10.x.G:** cast iron GG 25 (EN-GJL-250) varnished
- DG10.x.S:** cast steel GS-C 25 (1.0619/GP2406H)
- DG10.x.E:** stainless steel 1.4408

Sight Glass Materials:

- DG10.x.x.N:** soda lime glass (Tmax. 300 °F/ 150 °C) DIN 8902
- DG10.x.x.B:** borosilicate glass (Tmax. 280 °C) DIN 7080

Dimensions:

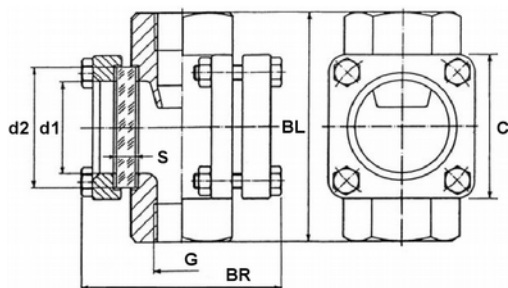

Con- nection	Qmax [l/min]*	BL [mm]	d1 [mm]	d2 [mm]	S [mm] 16 bar	C [mm]	BR [mm]
1/4"	9						
3/8"	14	100	32	45	10	70	95
1/2"	30						
3/4"	56	120	48	63	10	85	100
1"	88						
1 1/4"	144	160	65	80	12	116	125
1 1/2"	226						
2"	350	230 (GG: 180)	80	100	15	120	150

* with Rotor

Weight (without installation):

Connection	Cast Iron	Cast Steel or Stainless Steel
1/4"	2,2 kg	2,2 kg
3/8"+1/2"	2,2 kg	2,2kg
3/4"+1"	3,5 kg	3,5 kg
1 1/4"+1 1/2"	7,0 kg	7,0 kg
2"	10,0 kg	10,5 kg

Order Code:

Order Number: **DG10.** **RK.** **E.** **B.** **25.** **16.** **0**

Flow sight glass with threaded connections (female)

Designs:

- S = standard design with fully clear bore (sizes 1 1/4" and above with drip tube)
- K = with flap
- RK = with plastic rotor (POM) (not for 2")
- RP = with plastic rotor (PTFE)

Housing materials:

- G = cast iron (PN 16 only)
- S = cast steel
- E = stainless steel

Sight glass materials:

- N = soda lime glass
- B = borosilicate glass

Process connection (female):

- 08 = G 1/4 08N = 1/4" NPT
- 10 = G 3/8 10N = 3/8" NPT
- 15 = G 1/2 15N = 1/2" NPT
- 20 = G 3/4 20N = 3/4" NPT
- 25 = G 1 25N = 1" NPT
- 32 = G 1 1/4 32N = 1 1/4" NPT
- 40 = G 1 1/2 40N = 1 1/2" NPT
- 50 = G 2 female 50N = 2" NPT
- NPT- thread with cast steel + stainless steel

Pressure rating:

- 16 = 232 psi/ PN 16 (standard)
- 25 = 363 psi/ PN 25 (only cast steel or st. st. with borosilicate gl.)
- 40 = 580 psi/ PN 40 (only cast steel or st. st. with borosilicate gl.)

Options:

- 0 = without
- 1 = Please specify in plain text

Technical Data:

Materials: housing and sight glass: see description
gasket: graphite
(other gasket materials available on request)

Max. pressure: 232 psi/ PN 16 standard

580 psi/ PN 40 standard at size DN 08, 10 and 15 at cast steel or stainless steel

363 psi/ PN 25 and 580 psi/ PN 40 only optionally for cast steel + stainless steel

Max. media-temperature:

DG10.S/K...: 300 °F/ 150 °C (536 °F/ 280 °C with borosilicate glass)

DG10 RK...: 248 °F/ 120 °C

DG10.RP...: 300 °F/ 150 °C (500 °F/ 260 °C with borosilicate glass)

Special Designs:

Flow sight glasses with welding ends



PKP Prozessmesstechnik GmbH
Borsigstr. 24 • D-65205 Wiesbaden
☎ +49 (0) 6122-7055-0 • 📠 +49 (0) 6122 7055-50
✉ info@pkp.de • 🌐 www.pkp.de

PKP Process Instruments Inc.
10 Brent Drive • Hudson, MA 01749
☎ +1-978-212-0006 • 📠 +1-978-568-0060
✉ info@pkp-usa.com • 🌐 www.pkp-usa.com

DG11

Sight Flow Indicator with Flanged Connection

- applicable for liquids and gases
- available with DIN or ANSI flanges
- standard with drip tube, flap or rotor optionally available
- materials: cast iron, cast steel or stainless steel
- for pipes from 1/2"/ DN 15 up to 8"/ DN 200
- for media-temperatures up to 300 °F/ 150 °C, higher ratings up to 546 °F/ 280 °C optionally available
- pressure rating: 232 psi/ PN 16, 363 psi/ PN 25, 580 psi/ PN 40, higher pressure ranges optionally available

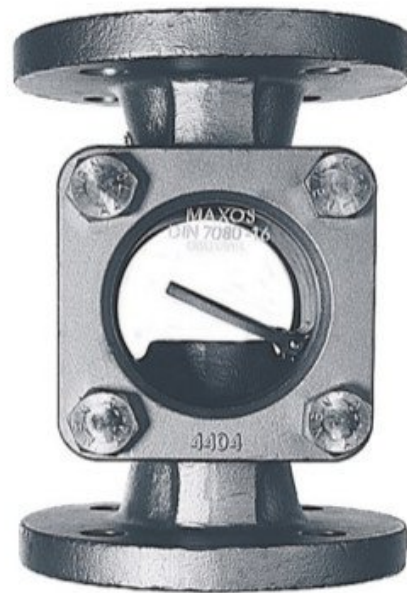

Description:

DG11 sight glasses are used to visually monitor the flow of liquids in pipe systems.

Depending on the type of liquid and flow volume, these devices are used with a fully clear bore or with a flap or rotor (for transparent liquids).

DG11 sight flow indicator permits reliable monitoring of the function and performance of single devices or entire systems.

Models:

Applications:

Because they are available in a variety of materials and designs, DG11 sight glasses can be used in almost any kind of pipe system.



PKP Prozessmesstechnik GmbH

Borsigstr. 24 • D-65205 Wiesbaden

☎ +49 (0) 6122-7055-0 • 📞 +49 (0) 6122 7055-50

✉ info@pkp.de • 🌐 www.pkp.de



PKP Process Instruments Inc.

10 Brent Drive • Hudson, MA 01749

☎ +1-978-212-0006 • 📞 +1-978-568-0060

✉ info@pkp-usa.com • 🌐 www.pkp-usa.com

- DG11.S:** standard model with drip tube (can be installed in any position)
- DG11.K:** with flap (can only be installed horizontally or for forward vertical flows)
- DG11.RK:** with rotor made of POM (Tmax. 248 °F / 120 °C, can be installed in any position)
- DG11.RP:** with rotor made of PTFE (Tmax. 500 °F / 260 °C, can be installed in any position)

Advice: Consider flow-direction

Housing materials (wetted parts):

- DG11.x.G:** cast iron GG 25 (EN-GJL-250) varnished
- DG11.x.S:** cast steel GS-C 25 (1.0619/GP2406H)
- DG11.x.E:** stainless steel (1.4408)

Sight Glass Material:

- DG11.x.x.N:** soda-lime glass (Tmax. 300 °F/ 150 °C) DIN8902
- DG11.x.x.B:** borosilicate glass (Tmax. 536 °F/280 °C) DIN7080

Dimensions:

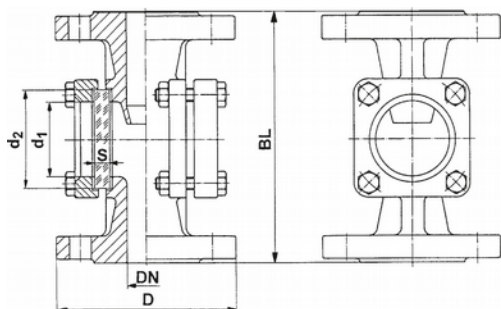

Advice: from DN 65 round glass cover

connection (DIN/ ANSI)	D [mm] PN 16	BL [mm]	d1 [mm]	d2 [mm]	S [mm] PN 16	weight [kg]*	
						G	S+E
15 / 1/2"	95	130	32	45	10	3,1	3,6
20 / 3/4"	105	150	32	45	10	4,0	4,0
25 / 1"	115	160	48	63	10	6,5	6,5
32 / 1 1/4"	140	180	48	63	12	7,0	7,5
40 / 1 1/2"	150	200	65	80	12	10,5	11,0
50 / 2"	165	230	80	100	15	14,0	14,5
65 / 2 1/2"	185	290	80	100	15	22,5	23,0
80 / 3"	200	310	100	125	20	30,0	32,0
100 / 4"	220	350	125	150	25	40,0	42,0
125 / 5"	250	400	150	175	25	47,0	47,0
150 / 6"	285	480	175	200	30	67,0	67,0
200 / 8"	340	600	175	200	30	118	118

bigger sizes on request

*) weight without installation

Order Code:

Order number: **DG11. RK. E. B. 25. A. 10. 0**

Sight glass flow indicator with flanged connection

Designs:

- S = standard-design with drip tube
 K = with flap
 RK= with plastic rotor (POM)
 (only up to DN 40, 1 1/2")
 RP= with plastic rotor (PTFE)

Housing materials:

- G = cast iron (PN 16 only)
 S = cast steel
 E = stainless steel

Sight glass material:

- N = soda lime glass
 B = borosilicate glass

Nominal size:

- 15...250 = ANSI 1/2" to ANSI 8"
 DN 15 to DN 200
 see table "Dimensions"

Process connection:

- A = ANSI Flange*
 D = DIN Flange

Pressure rate:

- 10 = PN 10 (standard from DN 150 and above)
 16 = PN 16 (standard up to DN 125, from DN 150 only with borosilicate glass) **
 25 = PN 25 (only up to DN 100 with borosilicate glass)
 40 = PN 40 (only up to DN 80 with borosilicate glass)

Options:

- 0 = without
 1 = Please specify in plain text

*) for 150 lbs only (300 lbs on request), ANSI flange in cast iron not for DN 100
 **) at sizes DN 15 and DN 20 in combination with cast steel or st. st. PN 40 is standard

Technical Data:

Materials: housing and sight glass: see description:
 gasket: graphite
 (other gasket materials on request)

Max. pressure: 145 psi/ 232 psi (10 / 16 bar)
 (higher pressure ratings optionally available)

Max. media-temperature:

- DG11.S/K...:** 300 °F/ 150 °C (536 °F/ 280 °C with borosilicate glass)
DG11 RK...: 248 °F/ 120 °C
DG11.RP...: 300 °F/ 150 °C (260 °C with borosilicate glass)

Special versions on request:

- sight glass plates sealed acc. to DIN 28121
- sight glass made of META glass (metall-merged sight glass plates acc. to DIN 7079) for particularly dangerous media
- welded version
- no dead space version
- angle- or 3-way version



PKP Prozessmesstechnik GmbH
 Borsigstr. 24 • D-65205 Wiesbaden
 ☎ +49 (0) 6122-7055-0 • 📠 +49 (0) 6122 7055-50
 ✉ info@pkp.de • 🌐 www.pkp.de

PKP Process Instruments Inc.
 10 Brent Drive • Hudson, MA 01749
 ☎ +1-978-212-0006 • 📠 +1-978-568-0060
 ✉ info@pkp-usa.com • 🌐 www.pkp-usa.com