

DK10

Flap Flowmeter and Switch

- for liquids
- robust design, can be installed in any position, insensitive to dirty/contaminated liquids
- suitable for pipes from 1/4" to 8"
- many different material combinations for practically all types of process liquids
- max. pressure: 200 bar, max. temperature: 330 °C
- for viscosities up to 600 cSt
- mechanical flow indication
- output signals: 4...20 mA, 1 or 2 Microswitches
-  Ex- version acc. to ATEX optional



Description:

The DK10 series flap flow meter comprises a spring-loaded flap mounted in a hemispherical chamber. The flap is deflected by the flow in the line. The deflection is directly proportional to the flow rate. The movement of the flap is transmitted via a shaft – that is sealed off from the process – to a mechanical pointer and the flow is displayed on a scale. One or two microswitches for flow monitoring or an analogue output module can be installed in the display enclosure (optional). Each flow meter is calibrated for the liquid being monitored based on customer specifications. The devices are available with G or NPT threads for 1/4" to 2" pipes and as a wafer for mounting between two DIN or ANSI flanges on DN 80 (3") to DN 200 (8") pipe sizes.

Typical applications:

Due to their robust design, their resistance to dirty or contaminated liquids and the variety of material combinations available, the DK10 flap flow meters are suitable for use as control and monitoring devices for practically all process liquids.

Models:

DK10... Flap flow meter with a directly coupled mechanical pointer

Materials:

Flaps and shafts are made of stainless steel as standard. Shafts made of titanium or Hastelloy, as well as plastic flaps, are available for aggressive / caustic liquids and for plastic models.

A	Aluminium (low-cost for oils), Tmax = 200 °C
B	Bronze (z. B. for sea water), Tmax = 250 °C
C	Cast iron (for general purpose applications), Tmax = 200 °C
CN	Cast iron, nickel plated (corrosion proof), Tmax = 200 °C
S	Cast steel, Tmax = 250 °C
V	St. st. 1.4408, ASME 316, ASTM - A - 351 CR8M, Tmax = 330 °C
PT	PTFE, Pmax = 7 bar, Tmax = 150 °C
PV	PVC, Pmax = 7 bar, Tmax = 60 °C

Gaskets:

The choice of sealing material depends on the liquid being monitored and the expected temperatures.

B	NBR (-40...+110 °C)
E	EPDM (-40...+150 °C)
V	FKM (-20...+200 °C)
PT	PTFE (-100...+250 °C)
PF	Perlast (Perfluorelastomer, -15...+330 °C)

Measuring ranges:

The quoted full scale value ranges serve as a rough guide for water. Within the specified limitations all measuring ranges can be realised.

E.g. unit S: 4-70 l/min;
smallest possible range 0...4 l/min,
largest possible range 0...70 l/min

Process-connection (G or NPT)	Con-nection code	Measurement range end values (full scale)			
		...LM [l/min]	...MH [m³/h]	...GM [U.S.gpm]	...GH [U.S.gph]
Unit size S					
1/4"/DN 10	1	4 - 70	0,24 - 4,2	1,0 - 18,5	60 - 1100
1/2"/DN 15	2	4 - 70	0,24 - 4,2	1,0 - 18,5	60 - 1100
3/4"/DN 20	3	4 - 70	0,24 - 4,2	1,0 - 18,5	60 - 1100
1"/DN 25	4	4 - 70	0,24 - 4,2	1,0 - 18,5	60 - 1100
Unit size M					
3/4"/DN 20	5	40 - 400	2,4 - 24	10 - 106	600 - 6300
1"/DN 25	6	40 - 400	2,4 - 24	10 - 106	600 - 6300
1 1/4"/DN 32	7	40 - 400	2,4 - 24	10 - 106	600 - 6300
1 1/2"/DN 40	8	40 - 500	2,4 - 30	10 - 132	600 - 8000
2"/DN 50	9	40 - 500	2,4 - 30	10 - 132	600 - 8000
2 1/2"/DN 65	9A	40 - 800	2,4 - 48	10 - 211	600 - 12.800
Unit size L					
3"/DN 80	10	120 - 1500	7,2 - 90	32 - 400	1900-23700
4"/DN 100	11	120 - 2000	7,2 - 120	32 - 530	1900-31700
6"/DN 150	12	120 - 3500	7,2 - 210	32 - 925	1900-55500
8"/DN 200	13	120 - 5000	7,2 - 300	32 - 1325	1900-79200

Order Code:

Order number: **DK10.** **B.** **B.** **G1.** **LM35.** **LP.** **1.** **M.** **R.**

Flap flowmeter and switch

Housing material:

A = aluminium
B = bronze
C = cast iron
CN = cast iron, nickel plated
S = cast steel
V = stainless steel
PT = PTFE
PV = PVC

Sealing material:

B = NBR
E = EPDM
V = FKM
PT = PTFE
PF = Perlast

Process connections and connection code:

G1...G9A = G 1/4 - G 2 female, measuring ranges 1-9A
N1...N9A = 1/4" NPT - 2 1/2" NPT female, measuring ranges 1-9A

FD1...FD13 = DIN flange and range 1...13 /xx = pressure rating PN 10, 16, 25, 40
FA1...FA13 = ANSI flange and range 1...13 /xxx = pressure rating 150, 300, 600 lbs

D10...D13 = wafer for DIN flanges, measuring ranges 10-13 (only for pressure rating LP)
A10...A13 = wafer for ANSI flanges, measuring ranges 10-13 (only for pressure rating LP)

Unit and full scale range:

(full scale value free choosable from table.
Example: LM35 at number of measuring range 3)
LM... = [l/min]
MH... = [m³/h]
GM... = [U.S. gpm]
GH... = [U.S. gph]

Pressure rating of housing:

VP = max 7 bar / 100 psi for plastic housing
LP = max. 20 bar / 300 psi
MP = max. 50 bar / 750 psi
HP = max. 200 bar / 3000 psi for cast and stainless steel
max. 100 bar / 1450 psi for cast iron

Viscosity of process media:

1...600 = please specify viscosity of liquid at operating temperature in cSt (mm²/s)

Output signals:

M = none, mechanical flow indication only
S1 = 1 microswitch, 3-pin changeover contact
S2 = 2 microswitches, 3-pin changeover contacts
SG1 = 1 microswitch, gold-plated contacts, 3-pin changeover
SG2 = 2 microswitches, gold-plated contacts, 3-pin changeover
(microswitches also available in ATEX version)
A2 = analogue output 4...20 mA, 2-wire, 8...28 V_{DC}
A3 = analogue output 4...20 mA, 3-wire, 8...28 V_{DC}

Direction of flow:

L = from left to right
R = from right to left
U = from bottom to top
O = from top to bottom

Technical Data (mechanical):

Max. pressure: 20 / 50 / 200 bar
300 / 750 / 3000 psi
plastic housing max. 7 bar / 100 psi

Medium-temperature: -100...+330 °C (depending on device materials and gasket material)

Accuracy: ± 3 % of full scale

Max. flow: min. 2 x full scale

Mounting position: any

Pressure rating:

VP max. 7 bar / 100 psi
LP max. 20 bar / 300 psi
MP max. 50 bar / 750 psi
HP max. 200 bar / 3000 psi (for cast iron, cast steel or st. steel housing only)

Limit contacts:

One or two electromechanical limit switches - that can be adjusted over the entire measurement range - can be fitted to DK10 flow meters.

Models

S1/S2: 1 or 2 microswitches as 3-pin changeover contact

Switching capacity:

15 A, 250 V
0,5 A, 125 V_{DC} /
0,25 A, 250 V_{DC}

Models

SG1/SG2: as for S1/S2, but with gold-plated contacts

Factory set switch point:

available on request

Electrical connection:

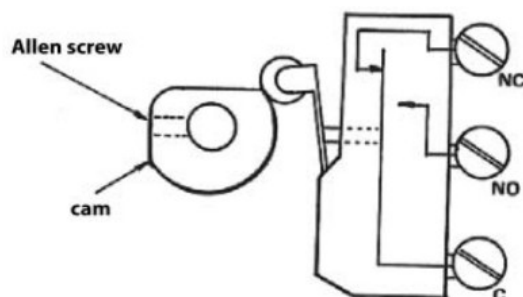

Analogue output:

The optional analogue output on the DK10 meter is available as a 2- or 3-wire circuit. It provides a 4...20 mA signal that corresponds with the calibrated measurement range.

Models:

A2: 2-wire-version
A3: 3-wire-version

Output range: 4...20 mA = 0...full scale (± 5%)

Linearity: ± 1 %

Repeatability: < 0,2 %

Supply: 8...28 VDC, 50 mA max.

Over-voltage protection: up to 30 V

Max. load-impedance:

A2: $R < (U-8 \text{ V})/0,02 \text{ mA}$

A3: $R < (U-3 \text{ V})/0,02 \text{ mA}$

Operating temperature: -40...+85 °C

Connection assignment:

A2 - 2-wire

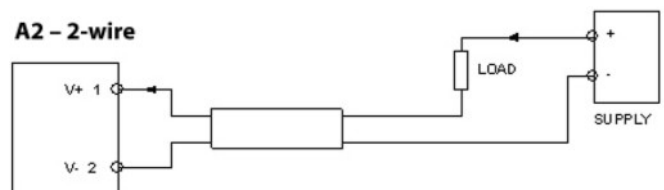

A3 - 3-wire

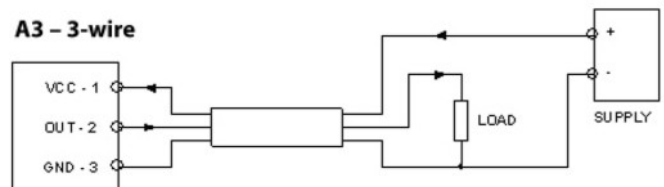

Dimensions:

Unit S:

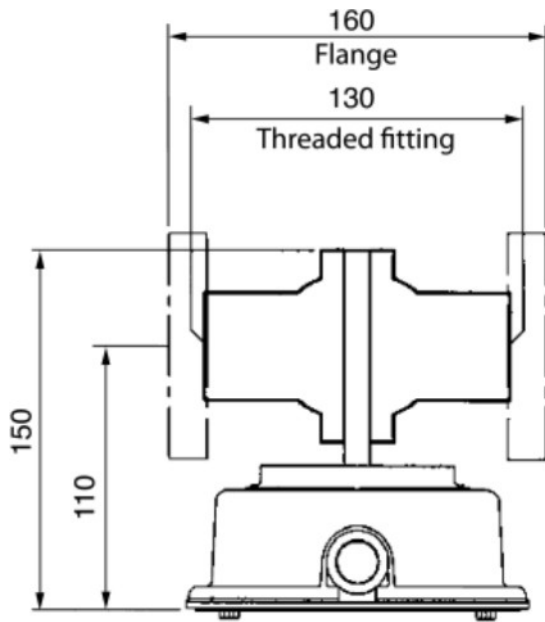

Unit M / L:

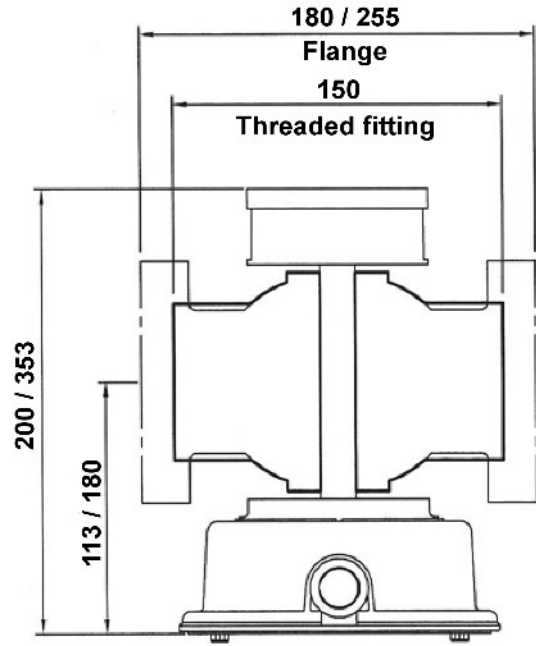

Flow

Unit L (wafer):

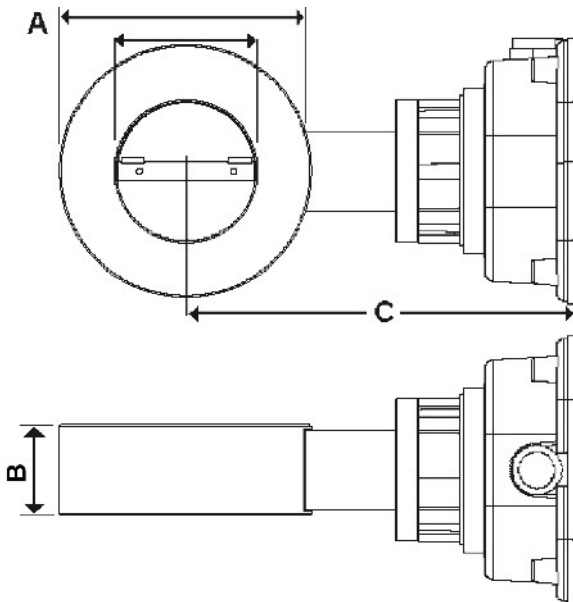

Size table wafer:

DN	A [mm]	B [mm]	C [mm]	ANSI	A [mm]	B [mm]	C [mm]
80	138	50	216	3"	127	50	210
100	158	50	226	4"	157	50	217
150	218	70	264	6"	216	70	263
200	278	70	291	8"	270	70	287