



Instruction Manual

DK10

Flap Flowmeter



PKP Prozessmesstechnik GmbH
Borsigstraße 24
D-65205 Wiesbaden-Nordenstadt
Tel.: ++49-(0)6122-7055-0
Fax: ++49-(0)6122-7055-50
Email: info@pkp.de

Table of Contents

Safety Information.....	2
Description of function.....	3
Installation.....	3
Electrical connection.....	4
Limit contacts.....	5
Analogue Output.....	5
Enclosure box rotation instructions / change of flow direction.....	5
Maintenance and Cleaning.....	6
Exploded View Drawing.....	7

Safety Information

General Instructions

To ensure safe operation, the device should only be operated according to the specifications in the instruction manual. The requisite Health & Safety regulations for a given application must also be observed. This statement also applies to the use of accessories.

Every person who is commissioned with the initiation or operation of this device must have read and understood the operating instructions and in particular the safety instructions!

The liability of the manufacturer expires in the event of damage due to improper use, non-observance of this operating manual, use of insufficiently qualified personnel and unauthorized modification of the device.

Proper Usage

The DK10 series flap-type flow meters are used to measure and display the flow of liquids that do not attack the materials used. All other usage is regarded as being improper and outside the scope of the device.

In particular, applications in which shock loads occur (for example, pulsed operation) should be discussed and checked in advance with our technical staff.

The series DK10 flow meter devices should not be deployed as the sole agents to prevent dangerous conditions occurring in plant or machinery. Machinery and plant need to be designed in such a manner that faulty conditions and malfunctions do not arise that could pose a safety risk for operators.

Dangerous substances

For dangerous media such as e.g. Oxygen, Acetylene, flammable or toxic substances as well as refrigeration systems, compressors, etc. must comply with the relevant regulations beyond the general rules.

Qualified Personnel

The DK10 devices may only be installed by trained, qualified personnel who are able to mount the devices correctly. Qualified personnel are persons, who are familiar with assembling, installation, placing in service and operating these devices and who are suitably trained and qualified.

Inward Monitoring

Please check directly after delivery the device for any transport damages and deficiencies. Additional with reference to the accompanying delivery note the number of parts must be checked.

Claims for replacement or goods which relate to transport damage can only be considered valid if the delivery company is notified without delay.

Description of function

The mechanical flow meter DK10 is used for quantitative flow indication of liquids. A baffle valve is deflected by the liquid flow. The deflection is transmitted mechanically via a shaft to a pointer which indicates the flow rate on a factory calibrated scale.

Installation

The flow indicators are in-line devices. Mounting can be in any position, and no straight length of pipe is required before or after the unit. The unit is sandwiched between two flanges. Under the Pressure Equipment Directive (PED) these products are Pressure Accessories, and are not approved for use as safety Accessories, as defined by the PED.

It is the responsibility of the user/installer of this equipment to ensure:

- ◆ Check that the maximum pressures and temperatures specified for the device are not exceeded by the pressures and temperatures in the process and that the materials used in the device for the parts in contact with the product are not attacked by the medium.
- ◆ Make sure that the pipelines have been cleaned and flushed before installation and that there are no foreign bodies in the pipeline.
- ◆ Avoid torsional stress on the instrument when installing it in the pipeline. Pressure shocks and vibrations, caused by e.g. sudden flow changes, can damage the instrument. Care must therefore be taken to ensure that valves are opened slowly to avoid pressure shocks.

Electrical connection

Attention:

Before connecting the device electrically, make sure that the supply voltage matches the required one and that the supply voltage is switched off.

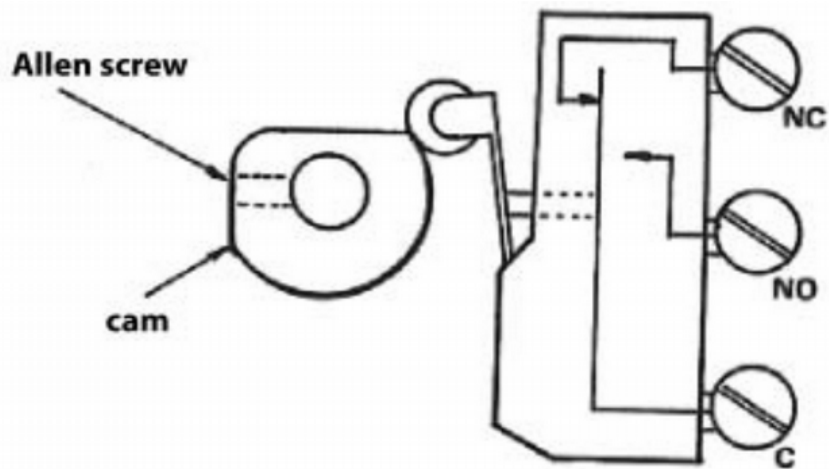

Pin assignment:

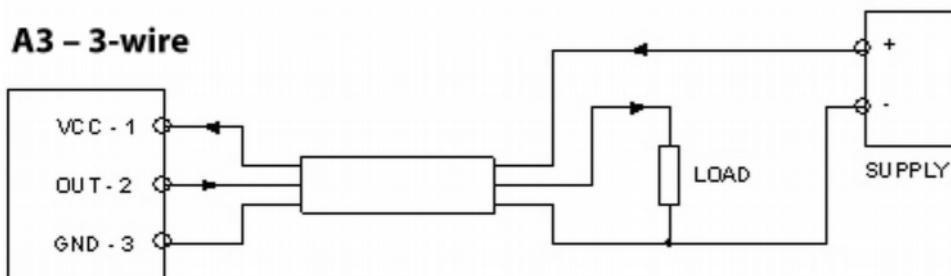
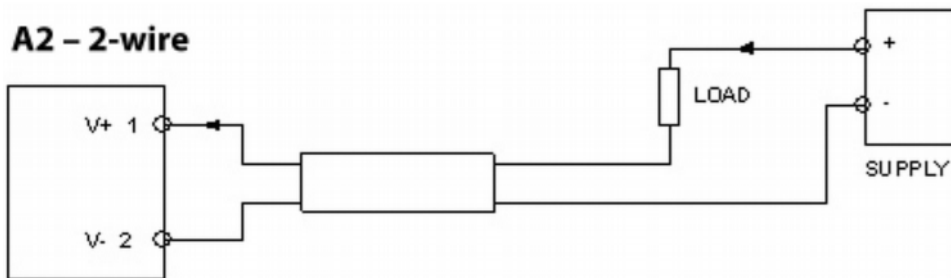

Limit contacts

The DK10 flowmeters can be equipped with 1 or 2 limit switches. The contacts are designed as 3-pole microswitches and are controlled by a cam.

The contacts can either be adjusted to a desired flow rate value at the factory when ordered or can be set directly by the user on site.

Contact adjustment:

- ◆ Loosen the 4 fixing screws of the housing cover and remove the cover as well as the disc underneath. Make sure that the seal is not damaged.
- ◆ The cam which operates the microswitch is situated on the spindle behind the pointer and can be adjusted to give an alarm anywhere between zero and max. flow. To alter the setting, lift the cam and rotate the cam in the direction required until switch point is located, then gently lower cam in that position.
- ◆ Put the O-ring back into the corresponding groove, put on the disc and the front plate and fix it again with the 4 screws.

Analogue Output

The optional analog output is set at the factory according to customer requirements and cannot be changed.

Enclosure box rotation instructions / change of flow direction

Tools required: Screw driver, Allen wrench set, nut driver

1. Remove 4 screws from nameplate.
2. Remove Name Plate and Window
3. Remove Calibrated Scale.
4. Remove Electrical Switch -Screw Driver (if monitor does not have switch(es) go to 5.)
5. Remove all 4 Allen Screws (4 mm Allen Wrench) at base of enclosure and rotate enclosure box to the desired position
6. Place 4 Allen Screws back into required tapped and tighten control box to meter body.
7. Loosen Indicator Pointer
NOTE: if monitor does not have switch(es) skip to 11.
8. "Slightly" Loosen Cam Set Screw just enough to move cam on dial. (DO NOT LOOSEN DIAL SET SCREW LOCATED BELOW THE CAM). This will make easier to tighten once switch contact point is set.
9. Place Switch back into enclosure box and tighten until snug - DO NOT OVER TIGHTEN
NOTE: Switch should be wired prior to re-installation
10. Rotate Cam to desired Set Point and tighten Allen Screw/Replace Compression Spring until snug. Cam will press against switch roller arm to actuate switch.
11. Place Calibrate Scale and tighten back in position. - DO NOT OVER TIGHTEN
12. Move Pointer to zero position on calibrated scale and tighten
13. Place Window then nameplate back on enclosure box and tighten Allen Screws.

Maintenance and Cleaning

1. Remove instrument from pipeline.
2. Remove from flanges (keep enclosure box and spring housing intact)
3. Check for and remove any swarf/foreign body, clean if necessary.
4. Remove faceplate and window
5. Check pointer is still firmly secured
6. Push open the valve plate, (depending on flow rate tension may be high), the valve plate will spring back to 0 when released. Repeat a few times at different points along the scale.
7. Listen/watch the switch to make sure it is activated at desired min/max flow as the valve plate is pushed open. (Adjust cam if necessary)
8. DO NOT remove or adjust springs as this will affect the calibration of the instrument.
9. Re-assemble instrument.

The instrument is only cleaned by washing with detergent, do not use abrasive cleaners or solvents.

Regular checks of the DK10 for function, corrosion/erosion and wear must be carried out by the manufacturer.

Exploded View Drawing

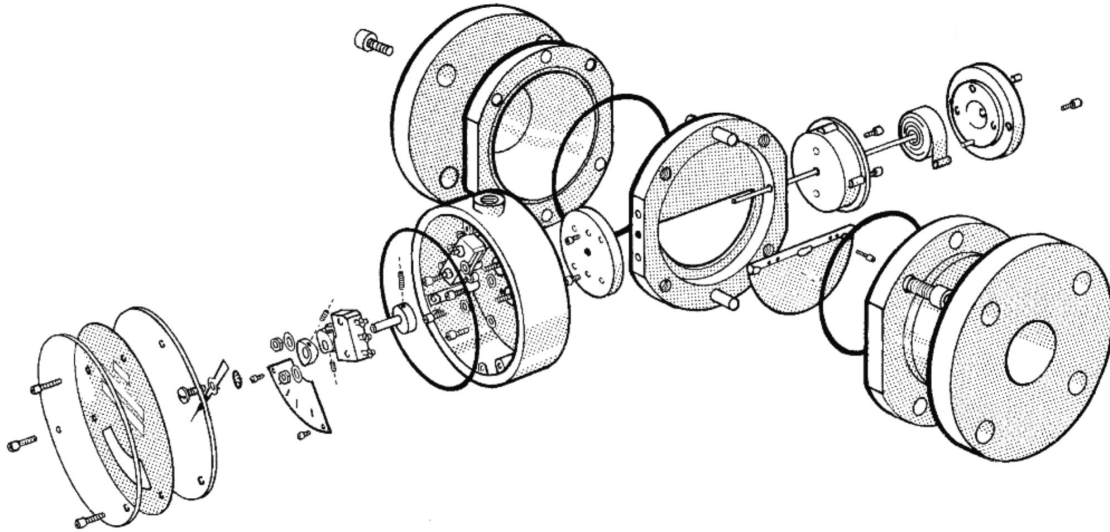

Item No.	Description
1.	Stud & Nuts
2.	O-Ring S1, S2, S3, S4
3.	Centre Housing AL, B, CI, CIK, S, SS, PVC
4.	Mounting Disc
5.	Enclosure Box
6.	Switch 3EE, 3EEG, 4EE, 6EE, 3EE(ATEX3), 3EE(ATEX2), 6EE(ATEX2), AIR, POT, OUT, DIG, TOT
7.	Dial Plate
8.	Screw
9.	Pointer
10.	(a) Rear O-Ring
10.	(b) Front O-Ring
11.	Face Plate
12.	Screw
13.	Plug
14.	Valve Plate
15.	Bowl AL, B, CI, CIK, S, SS, PVC
16.	O-Ring S1, S2, S3, S4
17.	Spindle
18.	Bearing
19.	Spring
20.	Screw
21.	Indicator Dial
22.	Cam
23.	Window
24.	Screw

Spares Kit

Item No.	Qty
2.	2-off
6.	1-off
8.	2-off
10.	1-off
16.	4-off
23.	1-off
24.	3-off

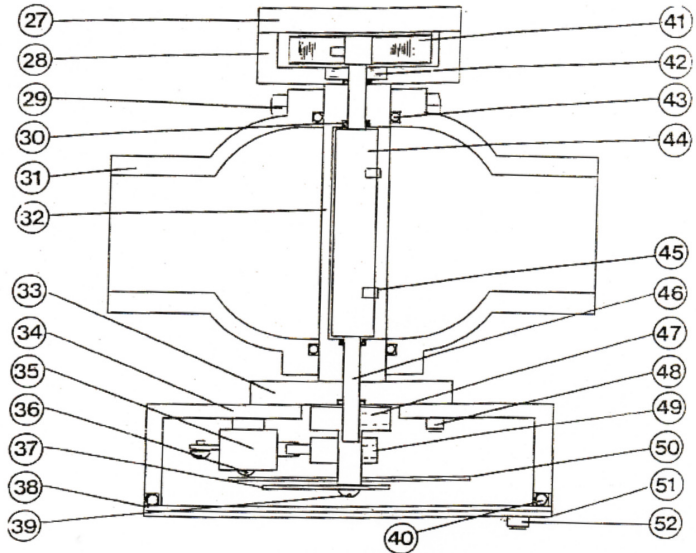

DK10

Flap Flowmeter and Switch

- for liquids
- robust design, can be installed in any position, insensitive to dirty/contaminated liquids
- suitable for pipes from 1/4" to 8"
- many different material combinations for practically all types of process liquids
- max. pressure: 200 bar, max. temperature: 330 °C
- for viscosities up to 600 cSt
- mechanical flow indication
- output signals: 4...20 mA, 1 or 2 Microswitches
-  Ex- version acc. to ATEX optional



Description:

The DK10 series flap flow meter comprises a spring-loaded flap mounted in a hemispherical chamber. The flap is deflected by the flow in the line. The deflection is directly proportional to the flow rate. The movement of the flap is transmitted via a shaft – that is sealed off from the process – to a mechanical pointer and the flow is displayed on a scale. One or two microswitches for flow monitoring or an analogue output module can be installed in the display enclosure (optional). Each flow meter is calibrated for the liquid being monitored based on customer specifications. The devices are available with G or NPT threads for 1/4" to 2" pipes and as a wafer for mounting between two DIN or ANSI flanges on DN 80 (3") to DN 200 (8") pipe sizes.

Typical applications:

Due to their robust design, their resistance to dirty or contaminated liquids and the variety of material combinations available, the DK10 flap flow meters are suitable for use as control and monitoring devices for practically all process liquids.

Models:

DK10... Flap flow meter with a directly coupled mechanical pointer

Materials:

Flaps and shafts are made of stainless steel as standard. Shafts made of titanium or Hastelloy, as well as plastic flaps, are available for aggressive / caustic liquids and for plastic models.

A	Aluminium (low-cost for oils), Tmax = 200 °C
B	Bronze (z. B. for sea water), Tmax = 250 °C
C	Cast iron (for general purpose applications), Tmax = 200 °C
CN	Cast iron, nickel plated (corrosion proof), Tmax = 200 °C
S	Cast steel, Tmax = 250 °C
V	St. st. 1.4408, ASME 316, ASTM - A - 351 CR8M, Tmax = 330 °C
PT	PTFE, Pmax = 7 bar, Tmax = 150 °C
PV	PVC, Pmax = 7 bar, Tmax = 60 °C

Gaskets:

The choice of sealing material depends on the liquid being monitored and the expected temperatures.

B	NBR (-40...+110 °C)
E	EPDM (-40...+150 °C)
V	FKM (-20...+200 °C)
PT	PTFE (-100...+250 °C)
PF	Perlast (Perfluorelastomer, -15...+330 °C)

Measuring ranges:

The quoted full scale value ranges serve as a rough guide for water. Within the specified limitations all measuring ranges can be realised.

E.g. unit S: 4-70 l/min;
smallest possible range 0...4 l/min,
largest possible range 0...70 l/min

Process-connection (G or NPT)	Con-nection code	Measurement range end values (full scale)			
		...LM [l/min]	...MH [m³/h]	...GM [U.S.gpm]	...GH [U.S.gph]
Unit size S					
1/4"/DN 10	1	4 - 70	0,24 - 4,2	1,0 - 18,5	60 - 1100
1/2"/DN 15	2	4 - 70	0,24 - 4,2	1,0 - 18,5	60 - 1100
3/4"/DN 20	3	4 - 70	0,24 - 4,2	1,0 - 18,5	60 - 1100
1"/DN 25	4	4 - 70	0,24 - 4,2	1,0 - 18,5	60 - 1100
Unit size M					
3/4"/DN 20	5	40 - 400	2,4 - 24	10 - 106	600 - 6300
1"/DN 25	6	40 - 400	2,4 - 24	10 - 106	600 - 6300
1 1/4"/DN 32	7	40 - 400	2,4 - 24	10 - 106	600 - 6300
1 1/2"/DN 40	8	40 - 500	2,4 - 30	10 - 132	600 - 8000
2"/DN 50	9	40 - 500	2,4 - 30	10 - 132	600 - 8000
2 1/2"/DN 65	9A	40 - 800	2,4 - 48	10 - 211	600 - 12.800
Unit size L					
3"/DN 80	10	120 - 1500	7,2 - 90	32 - 400	1900-23700
4"/DN 100	11	120 - 2000	7,2 - 120	32 - 530	1900-31700
6"/DN 150	12	120 - 3500	7,2 - 210	32 - 925	1900-55500
8"/DN 200	13	120 - 5000	7,2 - 300	32 - 1325	1900-79200

Order Code:

Order number: **DK10.** **B.** **B.** **G1.** **LM35.** **LP.** **1.** **M.** **R.**

Flap flowmeter and switch

Housing material:

A = aluminium
B = bronze
C = cast iron
CN = cast iron, nickel plated
S = cast steel
V = stainless steel
PT = PTFE
PV = PVC

Sealing material:

B = NBR
E = EPDM
V = FKM
PT = PTFE
PF = Perlast

Process connections and connection code:

G1...G9A = G 1/4 - G 2 female, measuring ranges 1-9A
N1...N9A = 1/4" NPT - 2 1/2" NPT female, measuring ranges 1-9A

FD1...FD13 = DIN flange and range 1...13 /xx = pressure rating PN 10, 16, 25, 40
FA1...FA13 = ANSI flange and range 1...13 /xxx = pressure rating 150, 300, 600 lbs

D10...D13 = wafer for DIN flanges, measuring ranges 10-13 (only for pressure rating LP)

A10...A13 = wafer for ANSI flanges, measuring ranges 10-13 (only for pressure rating LP)

Unit and full scale range:

(full scale value free choosable from table.
Example: LM35 at number of measuring range 3)
LM... = [l/min]
MH... = [m³/h]
GM... = [U.S. gpm]
GH... = [U.S. gph]

Pressure rating of housing:

VP = max 7 bar / 100 psi for plastic housing
LP = max. 20 bar / 300 psi
MP = max. 50 bar / 750 psi
HP = max. 200 bar / 3000 psi for cast and stainless steel
max. 100 bar / 1450 psi for cast iron

Viscosity of process media:

1...600 = please specify viscosity of liquid at operating temperature in cSt (mm²/s)

Output signals:

M = none, mechanical flow indication only
S1 = 1 microswitch, 3-pin changeover contact
S2 = 2 microswitches, 3-pin changeover contacts
SG1= 1 microswitch, gold-plated contacts, 3-pin changeover
SG2= 2 microswitches, gold-plated contacts, 3-pin changeover
(microswitches also available in ATEX version)
A2 = analogue output 4...20 mA, 2-wire, 8...28 V_{DC}
A3 = analogue output 4...20 mA, 3-wire, 8...28 V_{DC}

Direction of flow:

L = from left to right
R = from right to left
U = from bottom to top
O = from top to bottom

Technical Data (mechanical):

Max. pressure: 20 / 50 / 200 bar
300 / 750 / 3000 psi
plastic housing max. 7 bar / 100 psi

Medium-temperature: -100...+330 °C (depending on device materials and gasket material)

Accuracy: ± 3 % of full scale

Max. flow: min. 2 x full scale

Mounting position: any

Pressure rating:

VP max. 7 bar / 100 psi
LP max. 20 bar / 300 psi
MP max. 50 bar / 750 psi
HP max. 200 bar / 3000 psi (for cast iron, cast steel or st. steel housing only)

Limit contacts:

One or two electromechanical limit switches - that can be adjusted over the entire measurement range - can be fitted to DK10 flow meters.

Models

S1/S2: 1 or 2 microswitches as 3-pin changeover contact

Switching capacity:

15 A, 250 V
0,5 A, 125 V_{DC} /
0,25 A, 250 V_{DC}

Models

SG1/SG2: as for S1/S2, but with gold-plated contacts

Factory set switch point:

available on request

Electrical connection:

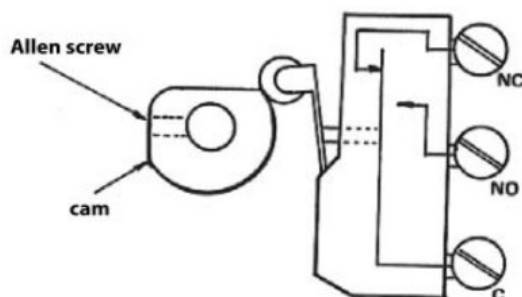

Analogue output:

The optional analogue output on the DK10 meter is available as a 2- or 3-wire circuit. It provides a 4...20 mA signal that corresponds with the calibrated measurement range.

Models:

A2: 2-wire-version
A3: 3-wire-version

Output range: 4...20 mA = 0...full scale (± 5%)

Linearity: ± 1 %

Repeatability: < 0,2 %

Supply: 8...28 VDC, 50 mA max.

Over-voltage protection: up to 30 V

Max. load-impedance:

A2: $R < (U-8 \text{ V})/0,02 \text{ mA}$

A3: $R < (U-3 \text{ V})/0,02 \text{ mA}$

Operating temperature: -40...+85 °C

Connection assignment:

A2 - 2-wire

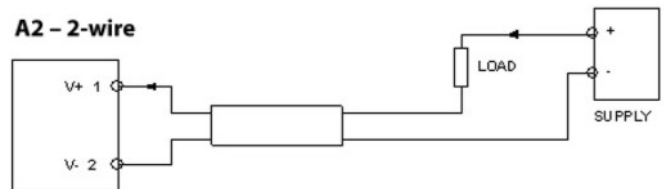

A3 - 3-wire

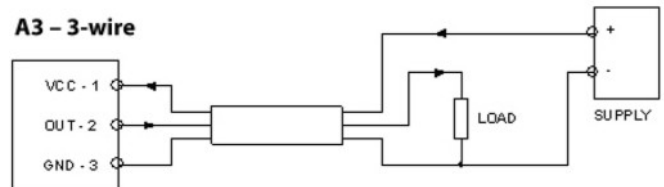

Dimensions:

Unit S:

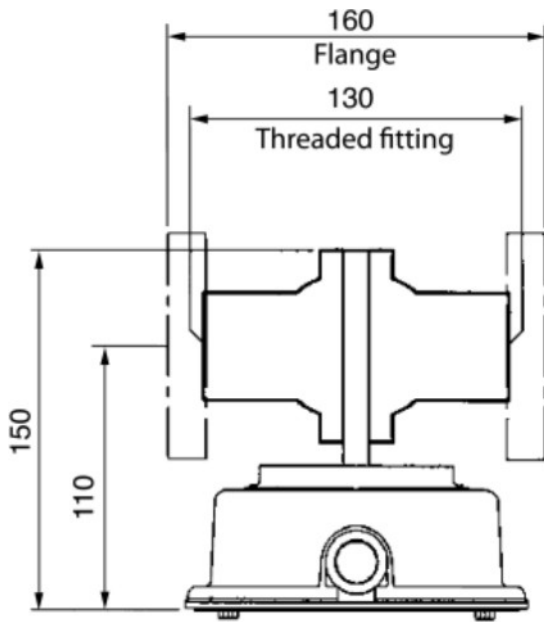

Unit M / L:

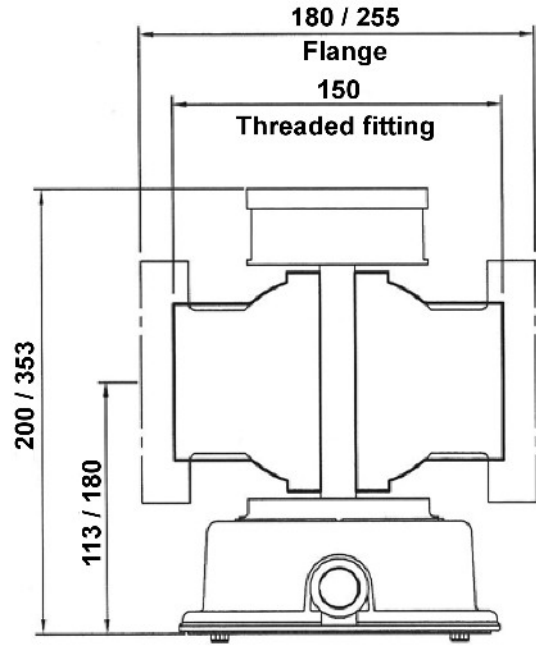

Flow

Unit L (wafer):

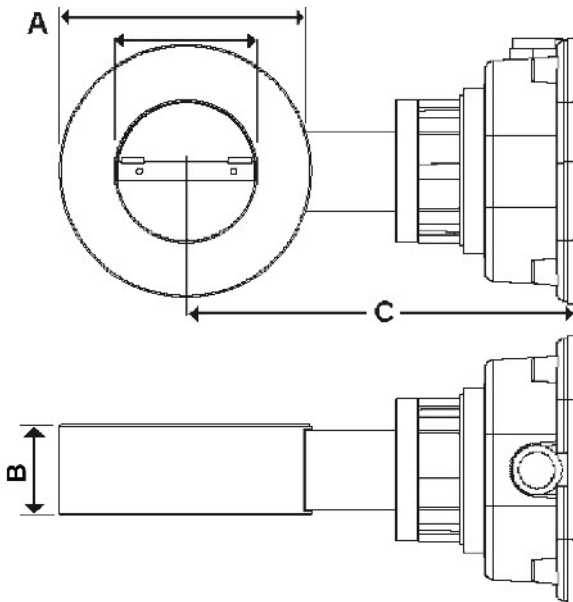

Size table wafer:

DN	A [mm]	B [mm]	C [mm]	ANSI	A [mm]	B [mm]	C [mm]
80	138	50	216	3"	127	50	210
100	158	50	226	4"	157	50	217
150	218	70	264	6"	216	70	263
200	278	70	291	8"	270	70	287