

# DK10

## Flap Flow Meters

- **robust design, can be installed in any position, insensitive to dirty/contaminated liquids**
- **suitable for 1/4" to 2" pipes with threaded fittings, and – as a wafer version – for 3" to 8" pipes**
- **many different material combinations for practically all types of process liquids**
- **max. pressure = 200 bar, max. temperature = 330 °C**
- **for viscosities up to 600 cSt**
- **mechanical flow indication**
- **electrical outputs: 4 - 20 mA, 1 or 2 microswitches**



### Description:

The DK10 series flap flow meter comprises a spring-loaded flap mounted in a hemispherical chamber. The flap is deflected by the flow in the line. The deflection is directly proportional to the flow rate. The movement of the flap is transmitted via a shaft – that is sealed off from the process – to a mechanical pointer and the flow is displayed on a scale. One or two microswitches for flow monitoring or an analog output module can be installed in the display enclosure (optional). Each flow meter is calibrated for the liquid being monitored based on customer specifications. The devices are available with G or NPT threads for 1/4" to 2" pipes and as a wafer for mounting between two DIN or ANSI flanges on DN80 (3") to DN200 (8") pipe sizes.

### Typical Applications:

Due to their robust design, their resistance to dirty or contaminated liquids and the variety of material combinations available, the DK10 flap flow meters are suitable for use as control and monitoring devices for practically all process liquids.

## Models:

**DK10...** Flap flow meter with a directly coupled mechanical pointer

## Materials:

Flaps and shafts are made of stainless steel for all device materials. Shafts made of titanium or Hastelloy, as well as plastic flaps, are available for aggressive/caustic liquids and for plastic models.

A Aluminum (low-cost for oils), Tmax = 200 °C  
 B Bronze (e.g. for sea water), Tmax = 250 °C  
 C Cast iron (for general-purpose applications), Tmax = 200 °C  
 CN Cast iron, nickel-plated (corrosion proof), Tmax = 200 °C  
 S Cast steel, Tmax = 250 °C  
 V Stainless steel, Tmax = 330 °C  
 PT PTFE, Pmax = 7 bar, Tmax = 150 °C  
 PV PVC, Pmax = 7 bar, Tmax = 60 °

## Gaskets:

The choice of sealing material depends on the liquid being monitored and the expected temperatures.

B Buna (Perbunan, -40 to +110 °C)  
 E EPDM (-40 to +150 °C)  
 V Viton (-20 to +200 °C)  
 PT PTFE (-100 to +250 °C)  
 PF Perlast (Perfluorelastomer, -15 to +330 °C)

## Measurement ranges:

The quoted measurement ranges serve as a rough guide only. The exact measurement ranges for a given device are calculated during manufacture based on the exact pipe diameter and calibrated in the devices.

Process connection (G or NPT)	Measurement range No.	Measurement ranges			
		L/min (...LM)	M <sup>3</sup> /h (...MH)	GPM (...GM)	GPH (...GH)
<b>Housing size S</b>					
1/4"	1	4 - 15	0.24 - 0.9	1.0...4.0	60 - 240
1/2"	2	4 - 30	0.24 - 1.8	1.0...8.0	60 - 480
3/4"	3	4 - 50	0.24 - 3.0	1.0...13.2	60 - 800
1"	4	4 - 70	0.24 - 4.2	1.0...18.5	60 - 1,100
<b>Housing size M</b>					
3/4"	5	40 - 100	2.4 - 6.0	10 - 26.4	600-1,600
1"	6	40 - 150	2.4 - 9.0	10 - 40.0	600-2,400
1 1/4"	7	40 - 220	2.4 - 13.2	10 - 58.0	600-3,500
1 1/2"	8	40 - 350	2.4 - 21.0	10 - 92.5	600-5,500
2"	9	40 - 500	2.4 - 30.0	10 - 132	600-8,000
<b>Housing size L (wafer)</b>					
DN80 / 3"	10	120 - 1,500	7.2 - 90	32 - 400	1,900-23,700
DN100 / 4"	11	120 - 2,000	7.2 - 120	32 - 530	1,900-31,700
DN150 / 6"	12	120 - 3,500	7.2 - 210	32 - 925	1,900-55,500
DN200 / 8"	13	120 - 5,000	7.2 - 300	32 - 1320	1,900-79,200

## Ordering Code:

**Order number:** **DK10. B. B. G2LM. MP. 1. M. R**

**Flap flow meter**

### Enclosure material:

A = Aluminum  
 B = Bronze  
 C = Cast iron  
 CN = Cast iron, nickel-plated  
 S = Steel casting  
 V = Stainless steel  
 PT = PTFE  
 PV = PVC  
 9 = custom material

### Sealing material:

B = Buna  
 E = EPDM  
 V = Viton  
 PT = PTFE  
 PF = Perlast  
 9 = custom gasket

### Measuring ranges and process connections

(please append to range code LM / MH / GM / GH for unit of measure):

G1...G9 = range 1-9, G ¼ female G2  
 N1...N9 = range 1-9, ¼" NPT female - 2" NPT female  
 D10...D13 = range 10-13, for flanges to DIN, DN 80-DN200  
 A10...A13 = range 10-13, for flanges to ANSI, 3"-8"  
 9 = custom range

### Pressure rating:

LP = max. 20 bar / 300 psi  
 MP = max. 50 bar / 750 psi  
 HP = max. 200 bar / 3000 psi  
 9 = custom design

### Viscosity of process liquid:

1 - 600 = please specify viscosity of liquid at operating temperature in cSt (mm<sup>2</sup>/s)

### Outputs:

M = none, mechanical flow indication only  
 S1 = 1 x microswitch, 3-pin changeover contact  
 S2 = 2 x microswitches, 3-pin changeover contact  
 SG1 = 1 x microswitch, gold-plated contacts, 3-pin changeover contact  
 SG2 = 2 x microswitches, gold-plated contacts, 3-pin changeover contact  
 A2 = analog output 4 - 20 mA, 2-wire, 8 - 28 VDC  
 A3 = analog output 4 - 20 mA, 3-wire, 8 - 28 VDC

### Direction of flow:

L = from left to right  
 R = from right to left  
 U = up  
 O = down

## Pressure Rating:

**LP** max. 20 bar / 300 psi  
**MP** max. 50 bar / 750 psi  
**HP** max. 200 bar / 3000 psi (for cast iron, cast steel or stainless steel enclosures only)

## Specifications (mechanical):

- Max. pressure:** 20 / 50 / 200 bar  
300 / 750 / 3000 psi  
plastic enclosure max. 7 bar / 100 psi
- Liquid-temperature:** -100 to +330 °C (depending on device materials and sealing material)
- Measurement uncertainty:** +/- 3% of end value
- Max. flow:** min. 2 x end value
- Installation position:** any

## Limit contacts:

One or two electromechanical limit switches - that can be adjusted over the entire measurement range - can be fitted to DK10 flow meters.

### Models

**S1/S2:** One or two microswitches as 3-pin changeover contact

### Switching

**capacity:** 15 A, 250 V  
0.5 A, 125 VDV /  
0.25 A, 250 VDC

### Models

**SG1/SG2:** as for S1/S2, but with gold-plated contacts

### Factory set

**switch point:** available upon request

## Electrical Connection:

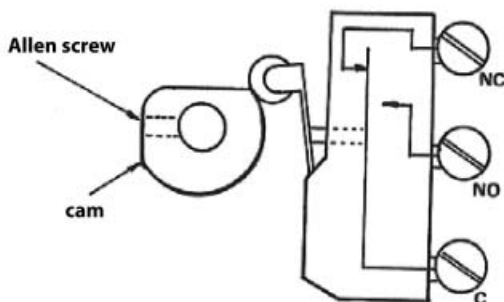

## Analogue output:

The optional analogue output on the DK10 meter is available as a 2- or 3-wire circuit. It provides a 4 - 20 mA signal that corresponds with the calibrated measurement range.

### Models:

**A2:** 2-wire circuitV

**A3:** 3-wire circuit

**Output range:** 4...20 mA = 0 - end value (± 5%)

**Linearity:** ± 1%

**Repeatability:** < 0,2%

**Supply:** 8 - 28 VDC, 50 mA max.

**Overvoltage protection:** max. 30 V

**Max. load impedance:**

**A2:**  $R < (U-8V)/0.02mA$

**A3:**  $R < (U-3V)/0.02mA$

**Operating temperature:** -40 to +85 °C

## Electrical Connection:

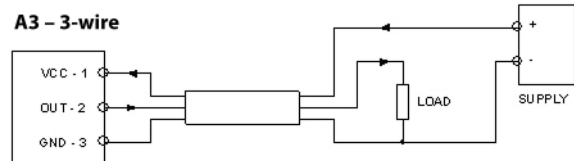
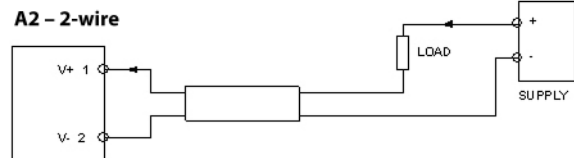

**Dimensions:**

**Chamber S:**

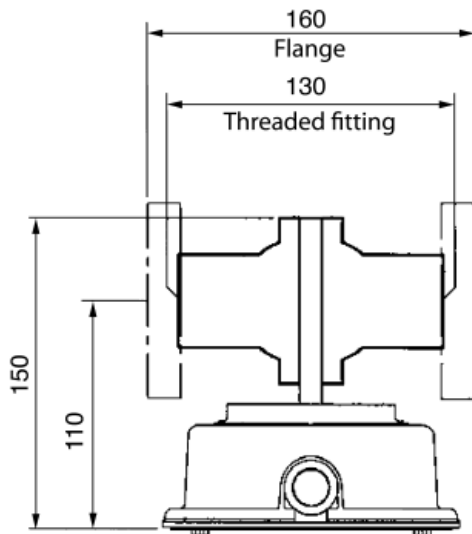

**Chamber M:**

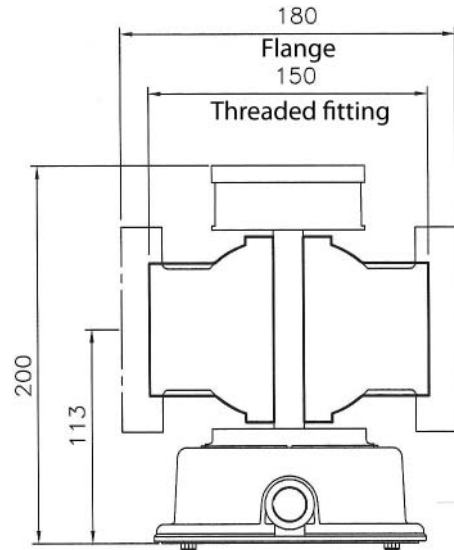

**Chamber L (wafer):**

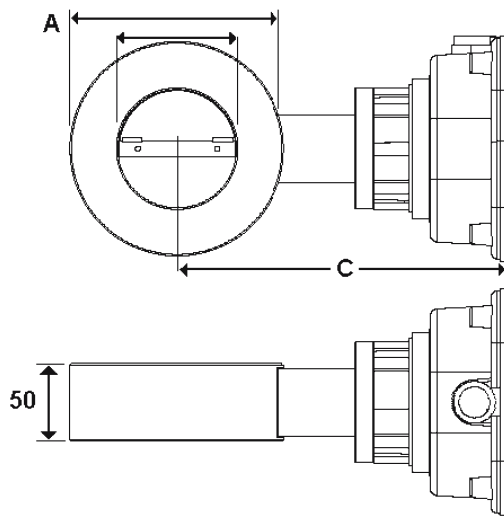

DN	A (mm)	C (mm)	ANSI	A (mm)	C (mm)
80	138	216	3"	127	210
100	158	226	4"	157	217
150	218	264	6"	216	263
200	278	291	8"	270	287