

Assembly- and Operating Instructions

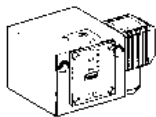

Pressure Switch PS05

Switching Housings



ABC XXX

ABC XXX-2 ...



Plug connection housing (200)
(Plug connection to DIN 43 650)

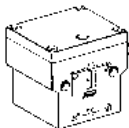

ABC XXX-3

ABC XXX-5 ...



Terminal connection housing (300 oder 500)

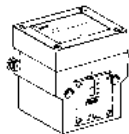

Ex-ABC

Ex-housing (700)

Important Note:

Pressure switches are precision instruments, set and adjusted at the factory. **Do not open the device or reset the varnished adjustment screw.** This would alter the switching points and resetting would be necessary.

Contents

1. Basic version
 - 1.1 Technical Data
 - 1.2 Electrical connection
 - 1.3 Pressure connection
 - 1.4 Setting the switching pressure
 - 1.5 Electrical interlock in the switchgear cabinet
2. Pressure monitors with adjustable switching difference
3. Pressure limiters with mechanical interlock of the switching state (restart lockout)
4. Pressure monitors with gold plated contacts
5. Two-stage pressure switch
6. Pressure monitors in intrinsically safe control circuits (EX-i)
7. Maximum pressure monitors in intrinsically safe control circuits with open-circuit and short-circuit monitoring (EX-i)
8. Pressure monitors in Ex version

1. Basic equipment of the pressure monitors

Chapter 1 describes the basic equipment and the installation of the pressure monitors (without any additional function). Chapters 2–7 deal with versions and additional functions.

1.1 Technical Data (not for Ex versions)

Switch

Single-pole changeover

Switching capacity

8 (5) A, 250 V AC

Installation position

Vertical and horizontal

Max. ambient temperature

–25 to 70 °C

Max. medium temperature

70 °C, higher medium temperatures are possible if the above limiting values at the switching device are not exceeded by suitable measures (e. g. water pocket tube). At ambient temperatures below 0 °C, ensure that no water condensation can arise in the sensor and in the switching device.

Switching difference

For values see data sheet

Pressure connection

External thread G 1/2 A (pressure gauge connection) according to DIN 16 288 and internal thread G 1/4 according to ISO 228, Part 1. (For gas applications internal tread permissible only up to 4 bar. Use flat gasket ring for pressure > 4 bar.

Switching device

Sturdy housing made of sea-water resistant aluminium die casting with plug connection (200) or terminal connection (300).

Degree of protection acc. to EN 60 529

IP 54 (housing 200)

IP 54 (housing 300)

Materials

see data-sheet

1.2 Electrical wiring

Connection layout

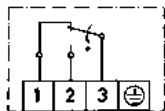

With rising pressure:
3-1 opens, 3-2 closes

With falling pressure:
3-2 opens, 3-1 closes

Wiring

Wiring is on the angled plug. The cable outlet can be in any of 4 positions, which are at 90° in relation to each other.

1. Remove screw
2. Insert the screwdriver in the slot and press downwards.

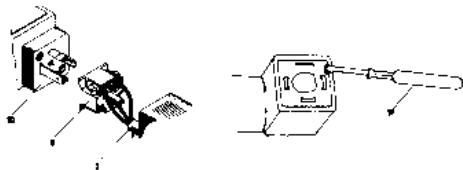

On devices with terminal connection housing (300 and 500) the terminal board is available after removing the terminal box lid.

Caution: Switch off voltage.

1.3 Pressure connection

1.31 Pressure switch

Installation: Directly on the pipeline (pressure gauge connection G 1/2") or with 2 screws (4 mm) on a level surface. Tighten only on the hexagonal of the pressure organ, never use the housing or plug as a lever arm.

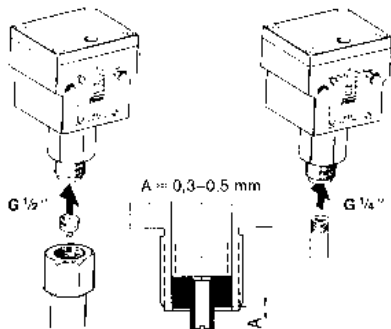

External thread G 1/2"
(Pressure gauge connection)

When using flat seals, turn in the centering screw (depth A approx. 0,3-0,5 mm).

Internal thread G 1/4"

In gas applications internal thread only up to 4 bar permissible. Use flat gasket ring for pressure > 4 bar.

1.32 Differential pressure switch

Pressure connection: 2 x G 1/4" internal thread.
Connect the high and the low pressure according marks. A mistake of the pressure connections may lead to malfunctioning.

1.4 Setting the switching pressure

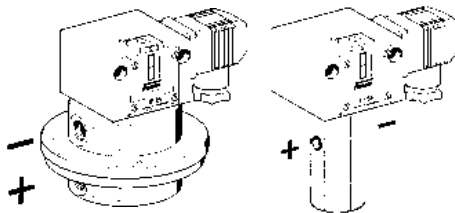
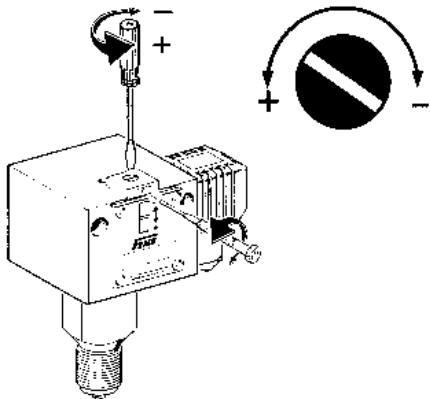

The switching pressure is set using the setting spindle. Before setting loosen the setscrew located above the scale by **approx. 2 turns** and tighten it again after setting.

The scale value corresponds to the upper switching point (for rising pressure). The lower switching point (for falling pressure) is lower by the switching difference. The scale serves as estimated value scale, a pressure gauge is required for accurate settings.

On terminal connection housings the setting screw is available after removing the cover.
Caution: Switch off voltage.

1.5 External electrical interlock in the switchgear cabinet

A pressure monitor can also be used as limiter if an electrical interlock is connected in series.

Examples:

Maximal pressure limitation

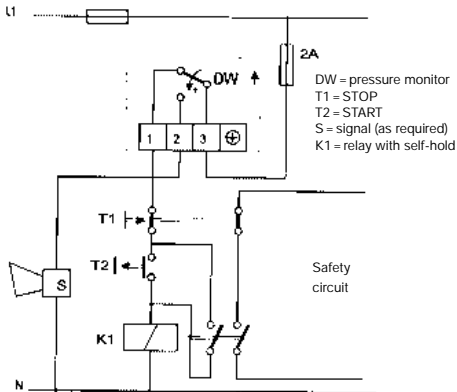

Minimal pressure limitation

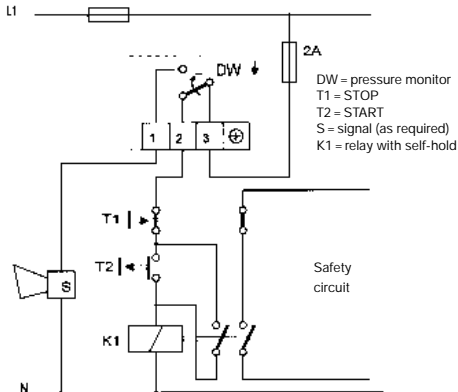

2. Pressure monitors with adjustable switching difference ...

2.1 Technical data as for 1.1

2.2 Electrical connection as for 1.2

2.3 Pressure connection as for 1.3

2.4 Setting

On spindle each is available for setting the switch pressure and the switching difference. Both spindles are arranged concentrically. The outer spindle with larger diameter influences the upper switching point, the switching difference and thus the lower switching point, is changed with the small grub screw located internally.

The action direction is indicated by the arrow direction.

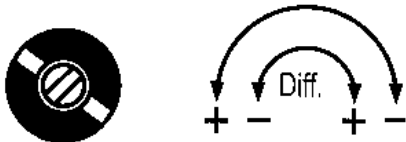

Setting sequence

- Lower switching (with decreasing pressure), with outer spindle, according to scale or pressure gauge
- Switching difference (with increasing pressure), with small, internal grub screw, results in lower switching point.

When the switching difference is changed, the lower switch-off point remains unchanged, the upper switching point is shifted by the switching difference.

$$RSP = SP - xd$$

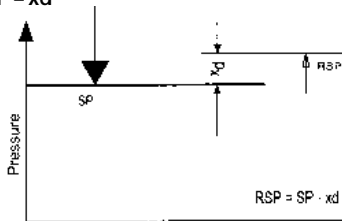

SP = switching point RSP = switch back point
xd = switching differences (hysteresis)

3. Pressure limiters with mechanical interlock of the switching state

Maximum pressure limiter ABC...-205

Minimum pressure limiter ABC...-206

Instead of the microswitch with automatic reset, a "bistable" microswitch is installed in the limiters.

When the pressure reaches the value set on the scale, the microswitch switches over and remains in this position. The catch can be released by pressing in the unlocking button (marked on the scale side of the switching device by a red dot). The limiter can not be unlocked until the pressure has decreased by a certain amount or, in the case of interlocking at the lower switching point, is increased again. According to version, the interlock can be effective for a rising value ABC ...-205 or for a falling value ABC...206.

3.1 Technical data as for 1.1

3.2 Electrical connection

3.2.1 Maximum pressure limiting

Switching over and interlocking on rising temperature.

Additional function (...205). Connection of control circuit to terminal 1 and 3.

3.2.2 Minimum pressure limiting

Switching over and interlocking on falling temperature.

Additional function (...206).

Connection of control circuit to terminal 2 and 3.

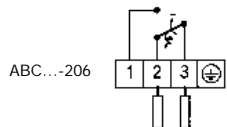
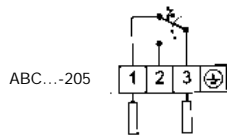
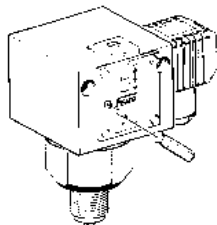

3.3 Pressure connection as for 1.3

3.4 Setting as for 1.4

Please note:

For maximum pressure limiters (205) the scale value corresponds to the upper switching point, for minimum pressure limiters (206) to the lower switching point.

4. Pressure limiters with gold plated contact ...-213

Gold plated contacts are used exclusively in the low voltage range in order to keep the transit resistance at the contacts low.

4.1 Technical Data as for 1.1

Switching capacity	max. 24 V DC
	max. 100 mA
	min. 5 V DC
	min. 2 mA

At higher voltages and currents, the gold layer on the contacts will be damaged.

All other data correspond to the basic equipment.

5. Two stage pressure switches

A switch unit with two microswitches both with single-poled changeover, forms part of the basic equipment for each two-stage pressure switch. The first switch I monitors lower pressure, the second switch II monitors higher pressure. It should be noted that the switching differentials of the individual microswitches cannot be exactly identical because of their component tolerances.

The switching interval of both microswitches is the interval (in bar or mbar) between the switching points of both microswitches.

5.1 Model

The switching interval between both switches is set according to the customer's requirements. With increasing pressure is firstly I microswitch (terminal connection 1-3) and then II microswitch (terminal connection 4-6) activated.

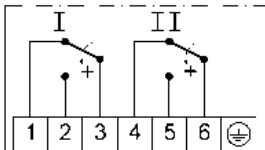

Applies for all variations:

Changes to the setting spindle, to the setting of switching pressure, do not lead to changes in the switching intervals as the switching points are adjusted correspondingly.

The switching differential of the individual microswitches corresponds to the switching differences listed under basic equipment.

The switching differential cannot be set for individual microswitches in two-stage pressure switches.

The switching points can moved parallelly to the setting spindle.

5.2 Model

Both microswitches are connected internally according to the given switching schedule (see label next to the plug connection). The switching interval is set according to customer specifications. The switching points can be moved parallelly to the setting spindle, however the switching interval can be set within given limits.

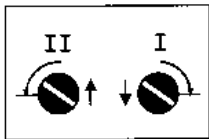

Setting wheel I CW –
reduce switching
point a microswitch I
Setting wheel II CCW –
raise switching
point at microswitch II

Setting wheels I and II have an internal stop to ensure that the microswitches cannot be adjusted past their effective range.

Electrical wiring ...217

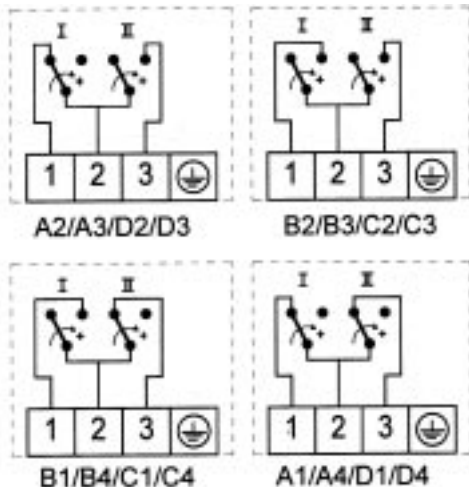

Note the sticker besides the plug connection of pressure switch.

5.3 Adjustment

Addition of the adjustment with setting wheels I and II provides the switching interval between the two microswitches. Changes made at the setpoint spindle do not affect the switching interval; the switching interval remains constant over the entire adjustment range of the spindle, the two switching points being displaced up or down in parallel.

1. Turn setting wheel I fully CCW.
Turn setting wheel II fully CW.
The lowest switching interval is adjusted.
2. Set setpoint spindle **S** to a value on the scale which is central between the required top and required bottom switching point.
3. With pressure applied, set bottom switching point with setting wheel I (a1).
4. With setting wheel II, proceed as under 3. above to set top switching point (a2).
5. If the required top and bottom switching point cannot be obtained, adjust setpoint spindle **S** in the necessary direction and repeat setting as per 3. and 4. above.

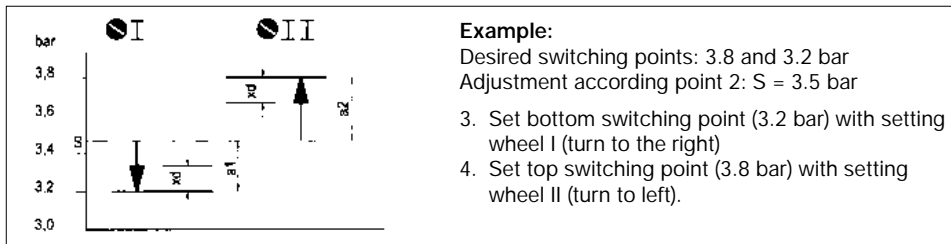

6. Pressure monitors in intrinsically safe control circuits (EEx-i) ...513

Pressure switches which are intended for EEx-i installations are equipped with blue terminals and cable entries.

Additional function ...513 is used together with suitable isolating switching amplifier, e.g. Ex 011.

Connection diagramm

Applies for maximum pressure monitoring. When using for minimum pressure monitoring, terminals 3 and 2 of pressure switch must be connected with terminals 1 and 2 of isolating switching amplifier.

Pressure monitors with additional function ...213 are connected as above mentioned to isolating switching amplifier Ex 011.

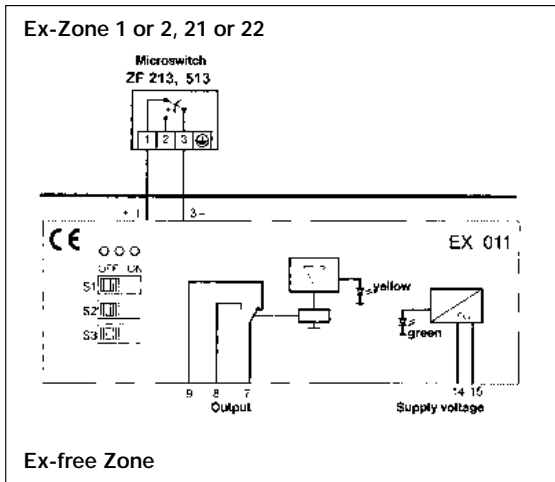

7. Pressure limiters / Pressure monitors in intrinsically safe control circuits with open-circuit and short-circuit monitoring (EEx-i)

The pressure monitors correspond in all technical data to the Type PS05. In addition, a resistance combination is provided in the switching device, which, together with the isolating amplifier EX 041, monitors the electric cables between isolating amplifier and pressure monitor for open circuit or short circuit. In the case of open circuit or short circuit, the system switches off towards the safe side. When choosing the type and when connecting please strictly distinguish between maximum pressure and minimum pressure monitoring, as well as monitoring and limitation function.

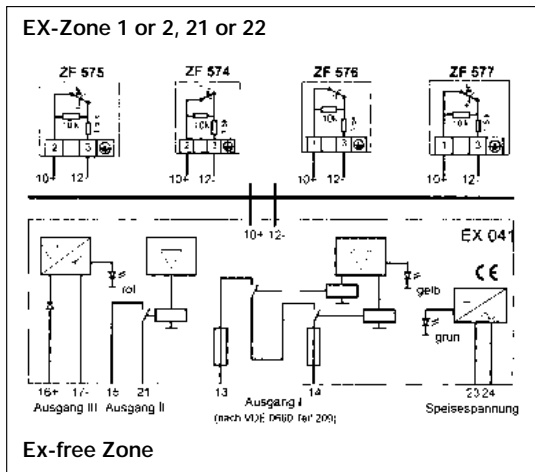

8. Pressure monitors in EEx-d version (Ex-...)

Pressure monitors in Ex version can be delivered only in a design tested by the PTB. Versions and additional functions are basically not possible.

8.1 Technical data of the Ex switching device

Type of Ex-protection

EX II 2 G D EEx de IIC T6 IP65 T80°C

PTB-authorization

PTB 02 ATEX 1121

Ex-Zone

Compatible for zones 1 and 2, 21 and 22

Form of protection

IP 65 (vertical position)

Ambient temperature

-15 to +60 °C

Max. temperature at pressure switch

60 °C

Max. medium temperature for pressure switches

60 °C. Higher medium temperatures are possible if the appropriate measure (e. g. water sack pipe) are taken so that the above mentioned ranges are not exceeded on the switch.

Cable type

M16 x 1.5

Switching difference

Not adjustable, approximate values see data sheet.

Fitting position

vertically upwards.

8.2 Electrical data

Connection plan: The terminal board can be accessed after the protective casing has been removed. After connecting the supply lines, the protective casing should in all cases be reattached.

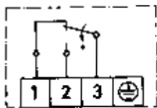

With increasing pressure 3–1 will be interrupted and 3–2 will be closed.

Switching element: Single-poled, changeover microswitch.

Protection of the conductive connection: Can be accessed after removing the terminal board casing.

Earthing connection / potential equalisation: External on the outside of the switching unit. The maximal cross section of the cable is 4 mm².

Switching power:

3 A 250 V AC, 2 A 250 V AC (inductive)

0,03 A 250 V DC, 3 A 24 V DC

8.3 Pressure connection as for 1.3

8.4 Setting of switching point

The switching point can be set within the range given in the datasheet by using a screwdriver on the setting spindle.

Additionally you should remove the terminal board casing (with 4 hexagon screw M 4).

The affixing screw on the front end (above the scale) has to be removed and should be reattached after setting the switching point.

Turning the setting spindle clockwise gives a lower switching point, turning anticlockwise gives a higher switching point.

The scale should be used as a guide, for more exact settings you should use a manometer.

8.5 Serial numbers

All switch units and their respective terminal board casings are marked with a serial number.

When installing you should ensure that the terminal board casings do not get mixed up.

Important notice

When installing the Ex switch units and setting them up for operation you should comply with the recognised rules and guidelines for installations in Ex-areas.

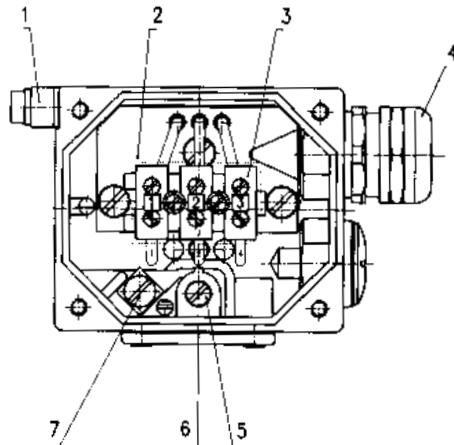

- 1 Potential equalisation
- 2 Protective casing for terminals (removable)
- 3 Connection terminals
- 4 Cable inlet M16 x 1.5
- 5 Switching point adjustment
- 6 Locking bolt for setting spindle
- 7 Protection of the conductive connection

