



PKP Prozessmesstechnik GmbH

Borsigstrasse 24

D-65205 Wiesbaden-Nordenstadt

Tel: 06122 / 7055 - 0

Fax: 06122 / 7055 – 50

Operating Instructions

PMR02 / PMR04

Bourdon Tube Pressure Gauge

Contents

1 Introduction	2
2 Safety Information	2
3 Functional Description	3
4 Installation	3
5 Maintenance	3
6 Limit Switches	4
7 Specification	see data sheet in the appendix

1 Introduction

Series PMR02 / PMR04 pressure gauges are noted for their reliable function and easy operation. To obtain the greatest benefit from this device, please observe the following cautionary statement:

Persons who are responsible for setting up or operating this device must be sure to read the and understand the operating instructions and the safety information pertaining to it.

2 Safety Information

2.1 General Instructions

To ensure safe operation, the device must only be operated according to the information in the operating instructions. When the device is in use, the regulations and safety standards applicable to the specific application must also be observed. This statement also applies to the use of accessories.

2.2 Proper Usage

Series PMR02 / PMR04 pressure gauges are designed for measuring and monitoring process pressures. Any application extending beyond this specific intended use does not constitute proper usage. Series PMR02 / PMR04 must not be employed as the sole means of avoiding hazardous conditions in machinery and installations.

The machinery and installations must be designed in such a manner that faulty conditions and malfunctions will not present hazardous situations for operating personnel.

2.3 Qualified Personnel

Series PMR02 / PMR04 must only be used by qualified, knowledgeable personnel trained in correct use of these devices. Qualified personnel are those persons familiar with setting up and assembling these devices, placing them in service and operating them. In addition, such personnel must also be qualified to perform the work associated with the application for which the device is being used.

3 Functional Description

A coiled, drawn brass or stainless steel tube filled with the fluid or gas being monitored is deformed to an extent depending on the pressure exerted by the fluid or gas. The resulting movement of the coil is transmitted to an indicator mechanism with a graduated display.

4 Installation

For connections with cylindrical screw threads, use suitable gaskets to seal the pressure gauge connections to the sealing face. For connections with tapered thread (e.g. NPT screw thread), apply a sealing component such as Teflon tape directly to the screw threads (EN 837-2). In order to be able to bring the measuring device into a position where it can be most easily read, we recommend the use of a tension bushing or gland nut.

During installation and removal, pressure gauges must not be turned by the housing. Be sure to only tighten and loosen gauges with suitable wrenches at the hexagonal drive points provided for this purpose.

If the pressure gauge is to be installed below the pressure tapping point, then the process line must be thoroughly flushed out first to remove any foreign objects before the gauge is installed. Some device models have a pressure-relief opening that can be vented and closed to equalize the internal pressure. In as-delivered condition, this pressure-relief opening is closed. Before checking these devices and/or after installation but before placing them in service, these devices must be vented (refer to label on housing). When pressure testing or purging piping systems or tanks, make sure that the pressure gauge is not subjected to pressure beyond the upper scale value. If this cannot be ensured, the pressure gauge must first be isolated or removed from the system. Before removing the pressure gauge, be sure to relieve the pressure in the measuring element. To do this, it may also be necessary to relieve the pressure in the process line.

Caution: Exposure to residue and deposits of materials being measured may pose a danger to people, the environment and the apparatus.

Be sure to follow proper safety procedures. Pressure gauges with measuring elements filled with water or mixtures containing water must be protected against frost.

5 Maintenance

Mechanical pressure gauges are maintenance-free.

The measuring accuracy (as defined per DIN EN 837) of the pressure gauge should be checked regularly. Inspection or recalibration should only be performed by trained, qualified personnel with suitable equipment.

Caution: If the pressure gauge is being used to monitor **hazardous substances** such as oxygen, acetylene, flammable or combustible materials, or poisonous materials and/or being used in **refrigeration systems, compressors**, etc., then the regulations applying in such cases must be also be observed in addition to the ones generally applicable. Be sure to take appropriate precautions and follow proper safety procedures.

6 Limit Switches

6.1 Magnetic spring contact

The electrical connection must only be installed by trained, qualified personnel. The connection assignments and the circuit functions are indicated on the device model plate. The connecting terminals (1 through 6) and the ground terminal are also identified. The lines connected to the main power source must be sized to handle the highest power consumption of the device and must comply with the IEC 227 or IEC 245 electrical codes. The necessary electrical data and specifications can be found in the appendix to these instructions.

Caution: When installing these devices, placing them in service and operating them, be sure to observe all applicable national safety standards (e.g. German standard VDE 0100). Any and all work must only be performed with the system de-energized. Failure to observe the applicable regulations may result in severe bodily injury and/or property damage. Only trained, qualified personnel may work on these devices.

6.2 Setting the setpoint indicator

The setpoint value is set at the view window with the supplied adjustment wrench. The setpoint indicators for the limit switch can be freely adjusted as required throughout the entire scale range. To ensure the switching accuracy, switching reliability and service life of the mechanical measuring systems, the switching points should not be set in the areas from 0 to 10% or from 90 to 100% of their respective measuring range.

6.3 Inductive contact

The setpoint value is set at the adjustment lock in the viewing window by means of the adjustment wrench (supplied).

The connection assignments and the circuit functions are indicated on the device model plate. The setpoint indicators for the limit switch can be freely adjusted as required throughout the entire scale range. To ensure the switching accuracy, switching reliability and service life of the mechanical measuring systems, the switching points should lie within 10% and 90% of the measuring range. The necessary electrical data and specifications can be found in the appendix to these instructions.

PMR02

Bourdon Tube Pressure Gauge

- Housing diameter 60 mm
- Accuracy class 1.6
- Steel or stainless steel housing
- Measuring mechanism and connection of brass or stainless steel
- Filled or unfilled
- Protection type IP 65

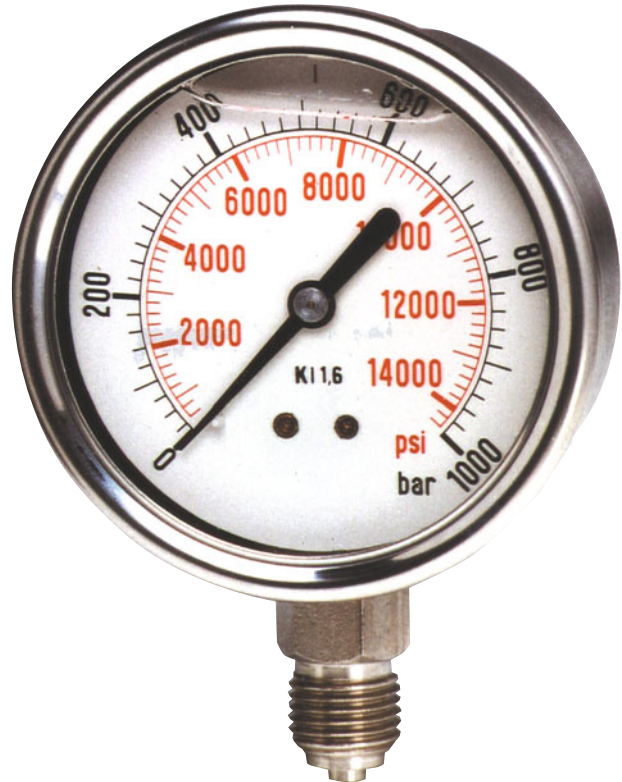

Description:

Model series PMR02 Bourdon tube pressure gauges can be supplied in brass or stainless steel versions, with filled or unfilled gauges. A coiled, drawn brass or stainless steel tube filled with the fluid or gas being monitored is deformed to an extent depending on the pressure exerted by the fluid or gas. The resulting movement of the coil is transmitted to an indicator mechanism with a graduated display. This movement can be dampened by means of an optionally available glycerin filling so that any vibrations have far less impact on the accuracy and stability of the reading. The natural lubricating properties of this glycerin filling also reduce wear to moving parts, entry of caustic/corrosive gases and accumulation of condensation. The stainless steel version allows pressure measurement of even the most caustic liquids and gases. These pressure gauges can be optionally fitted with a G1/4 A threaded connection at the bottom or on the back.

Applications:

Bourdon tube gauges are used throughout industry and are especially suitable for taking measurements at locations where there is no supply of electrical power available. Model series PMR02 Bourdon tube pressure gauges, of either steel or brass, are frequently used in industrial machinery and systems, on pumps, compressors, or block-type thermal power stations (BTTPs) since in these applications they only need to meet minimal requirements for withstanding the effects of the media being monitored. In contrast, chemical-service grade PMR02 Bourdon tube pressure gauges of stainless steel are designed to withstand contact with the very caustic/corrosive media often encountered in the chemical and petrochemical industries, the food and beverage industries, pharmaceutical production processes or in power plants, where they have provided the best service for decades.

Designs:

Nominal Sizes and Materials:

Housing diameter: 60 mm

PMR02.K: housing of carbon steel, black, connection of brass

PMR02.M: Housing of stainless steel, connection of brass with glycerin filling available only.

PMR02.E: Housing of stainless steel, connection of stainless steel

Process connection: G 1/4 at bottom or centered on back (carbon steel and brass version) or eccentric on back (stainless steel version)

Measuring Ranges: PMR02

Measuring range (bar)	Order code					
For all nominal sizes						
-1200...0 mbar**	A17	B17	C17 ¹	D17 ¹	E17	F17 ²
-1...0	A16	B16	C16	D16	E16	F16
-0.6...+1.0	A18	B18	C18	D18	E18	F18
-1...+0.6	A42	B42	C42	D42	E42	F42
-1...+1.5	A43	B43	C43	D43	E43	F43
-1...+3	A44	B44	C44	D44	E44	F44
-1...+5	A45	B45	C45	D45	E45	F45
-1...+9	A46	B46	C46	D46	E46	F46
-1...+15	A49	B49	C49	D49	E49	F49
0.2...1**	A50	B50	C50	D50	E50	F50
0...0.6**	A67	B67	C67	D67	E67	F67
0...1	A69	B69	C69	D69	E69	F69
0...1.6	A70	B70	C70	D70	E70	F70
0...2.5	A72	B72	C72	D72	E72	F72
0...4	A73	B73	C73	D73	E73	F73
0...6	A74	B74	C74	D74	E74	F74
0...10	A75	B75	C75	D75	E75	F75
0...16	A76	B76	C76	D76	E76	F76
0...25	A78	B78	C78	D78	E78	F78
0...40	A79	B79	C79	D79	E79	F79
0...60	A80	B80	C80	D80	E80	F80
0...100	A81	B81	C81	D81	E81	F81
0...160	A82	B82	C82	D82	E82	F82
0...250	A84	B84	C84	D84	E84	F84
0...400	A86	B86	C86	D86	E86	F86
0...600*	A87	B87	C87	D87	E87	F87
0...1000*	A88	B88	C88	D88	E88	F88

* measuring range not for PMR02.K

** measuring range not for PMR02.M

1 table section 65 mm

2 table section 63 mm

3 PMR02.M: frame coated black, optional chromed steel
PMR02.E: stainless steel frame

Model Coding:

Order number: PMR02. M. 1. 0. A49. 0

Bourdon tube pressure gauge

Materials:

K* = Housing of carbon steel, connection of brass
M = Housing of stainless steel, connection of brass³
E = Housing of stainless steel, connection of stainless steel
S = Special materials (please specify in writing)

Process connection:

1 = G 1/4 at bottom
2 = G 1/4 centered on back (PMR02.K and M only)
3 = G 1/4 eccentric on back (PMR02.E only)
9 = Custom connection

Vibration dampening:

0 = None
1 = With glycerin filling (for PMR02.M,E only)

Design and measuring ranges:

A17...F88 = see "Measuring Ranges" table

Options and accessories (more than one may be selected)

0 = None
xx = see "Options and Accessories" table

*) with glycerin filling only

Technical Details:

Housing: Round gauge housing of carbon steel, black, or stainless steel
d = 60 mm
Protection type IP45 (unfilled version)
Protection type IP65 (filled version)

Vibration dampening: Glycerin filling, with pressure-relief opening and inside pressure equalization

Pressure responsive element:

PMR02.K: Circular Bourdon tube up to 60 bar. Coiled Bourdon tube as of 60 bar

PMR02.M: Circular Bourdon tube, copper alloy, soldered in the connection shank
As of 100 bar, coiled Bourdon tube, stainless steel 1.4571, brazed in the connection shank

PMR02.E: Circular Bourdon tube
As of 100 bar, coiled Bourdon tube, stainless steel 1.4571

Indicator element:

PMR02.K,M: Brass, moving parts of nickel silver
PMR02.E: Stainless steel 1.4571/1.4301

Dial face:

aluminum, white face, black characters, as per EN 837-1

Viewing window:

PMR02.K: Instrument plexiglas
PMR02.M: Polycarbonate
PMR02.E: Multilayer safety glass

Accuracy:

Class 1.6

Maximum liquid temperature:

PMR02.K: 60°C
PMR02.M: - 25°C to 60°C
PMR02.E: 100°C

Overload protection:

PMR02.K: Short-term 1.0 times
PMR02.M,E: Short-term 1.3 times

Options and Accessories:

Description	Code	for model PMR02...
Protective cap of red rubber	GR	K
Protective cap of blue rubber	GB	K,M
Double-scale dial (e.g. bar/psi)	SD	all models
Refrigerant double-scale dial for pressure / R717 (NH3)	SK7	E
Print plate for creating special scale	SS1	all models
Measuring system free of oil and grease for use with oxygen	MO	all models
Measuring system free of silicone	MS	M,E
Measuring system with excess pressure protection >1.3 times	U	M,E
Connection shank: 1/4" NPT	Px	E
Red graduations on dial face	MR	all models
Red gliding mark pointer in the viewing window	ZR	all models
Red gliding mark pointer on the dial face	ZR1	all models

Designs:

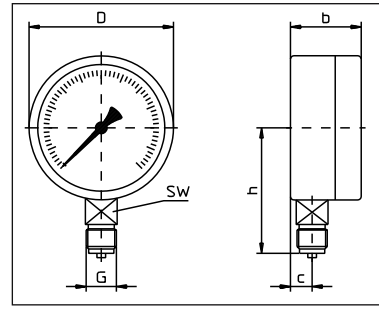

Design A:
Connection at bottom

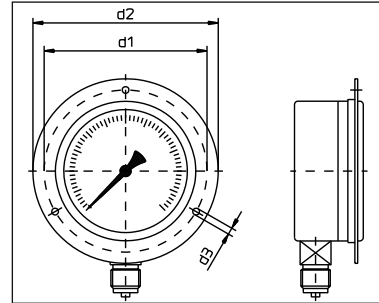

Design B:
Connection at bottom,
rim at front

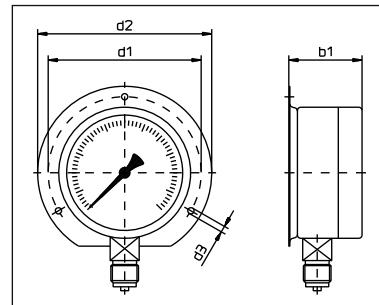

Design C:
Connection at bottom,
rim at back

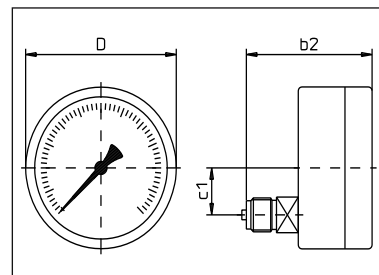

Design D:
Connection on back

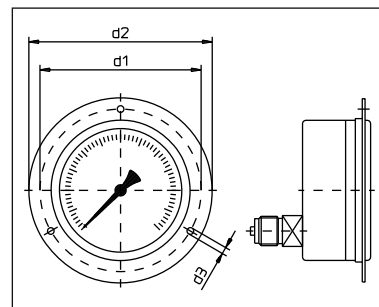

Design E:
Connection on back,
rim at front

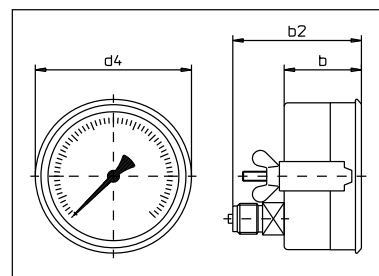

Design F:
Triangular front ring
and retaining clip

Dimensions:

Measurement:	Dimensions in mm
	PMR02
b	28.5
b1	46.5
b2	32.5
c	11
c1	18
D	63
d1	75
d2	85
d3	3.5
d4	67
h	84
SW	14
Weight (kg)	0.12