



PKP Prozessmesstechnik GmbH

Borsigstrasse 24

D-65205 Wiesbaden-Nordenstadt

Tel: 06122 / 7055 - 0

Fax: 06122 / 7055 – 50

Operating Instructions

PMP04

Diaphragm Pressure Gauge

Contents

1 Introduction	2
2 Safety Information	2
3 Functional Description	3
4 Installation	3
5 Maintenance	3
6 Specification	see data sheet in the appendix

1 Introduction

Series PMP04 pressure gauges are noted for their reliable function and easy operation. To obtain the greatest benefit from this device, please observe the following cautionary statement: **Persons who are responsible for setting up or operating this device must be sure to read the and understand the operating instructions and the safety information pertaining to it.**

2 Safety Information

2.1 General Instructions

To ensure safe operation, the device must only be operated according to the information in the operating instructions. When the device is in use, the regulations and safety standards applicable to the specific application must also be observed. This statement also applies to the use of accessories.

2.2 Proper Usage

Series PMP04 pressure gauges are designed for measuring process pressures. Any application extending beyond this specific intended use does not constitute proper usage. Series PMP04 must not be employed as the sole means of avoiding hazardous conditions in machinery and installations. The machinery and installations must be designed in such a manner that faulty conditions and malfunctions will not present hazardous situations for operating personnel.

2.3 Qualified Personnel

Series PMP04 must only be used by qualified, knowledgeable personnel trained in correct use of these devices. Qualified personnel are those persons familiar with setting up and assembling these devices, placing them in service and operating them. In addition, such personnel must also be qualified to perform the work associated with the application for which the device is being used.

3 Functional Description

Diaphragm pressure gauges have a thin, circular, dished diaphragm mounted between two flanges. One side of this diaphragm is exposed to the fluid. The deformation of the diaphragm caused by the fluid pressure is transmitted to a pointer element used to indicate pressure on a dial face.

4 Installation

For connections with cylindrical screw threads, use suitable gaskets to seal the pressure gauge connections to the sealing face. For connections with tapered thread (e.g. NPT screw thread), apply a sealing component such as Teflon tape directly to the screw threads (EN 837-2). In order to be able to bring the measuring device into a position where it can be most easily read, we recommend the use of a tension bushing or gland nut.

During installation and removal, pressure gauges must not be turned by the housing. Be sure to only tighten and loosen gauges with suitable wrenches at the hexagonal drive points provided for this purpose.

If the pressure gauge is to be installed below the pressure tapping point, then the process line must be thoroughly flushed out first to remove any foreign objects before the gauge is installed. Some device models have a pressure-relief opening that can be vented and closed to equalize the internal pressure. In as-delivered condition, this pressure-relief opening is closed. Before checking these devices and/or after installation but before placing them in service, these devices must be vented (refer to label on housing). When pressure testing or purging piping systems or tanks, make sure that the pressure gauge is not subjected to pressure beyond the upper scale value. If this cannot be ensured, the pressure gauge must first be isolated or removed from the system. Before removing the pressure gauge, be sure to relieve the pressure in the measuring element. To do this, it may also be necessary to relieve the pressure in the process line.

Caution: Exposure to residue and deposits of materials being measured may pose a danger to people, the environment and the apparatus.

Be sure to follow proper safety procedures. Pressure gauges with measuring elements filled with water or mixtures containing water must be protected against frost.

5 Maintenance

Mechanical pressure gauges are maintenance-free.

The measuring accuracy (as defined per DIN EN 837) of the pressure gauge should be checked regularly. Inspection or recalibration should only be performed by trained, qualified personnel with suitable equipment.

Caution: If the pressure gauge is being used to monitor **hazardous substances** such as oxygen, acetylene, flammable or combustible materials, or poisonous materials and/or being used in **refrigeration systems, compressors**, etc., then the regulations applying in such cases must be also be observed in addition to the ones generally applicable. Be sure to take appropriate precautions and follow proper safety procedures.

PMP04

Diaphragm Pressure Gauge

- For caustic/corrosive, highly viscous, crystallizing fluids
- Unaffected by shocks and vibrations
- High protection against overpressure



Description:

Diaphragm pressure gauges have a thin, circular, dished diaphragm mounted between two flanges. One side of this diaphragm is exposed to the fluid. The deformation of the diaphragm caused by the fluid pressure is transmitted to a pointer element used to indicate pressure on a dial face. Diaphragm pressure gauges are unaffected by shock and vibration and can be optionally supplied with high protection against overpressure. With appropriate diaphragm coatings, these devices can be used under rough/extreme service conditions and with caustic/corrosive fluids.

Applications:

Due to their principle of design, and with the correct selection of materials, diaphragm pressure gauges can be used under the rough/extreme service conditions that occur in industrial production. Their open connecting flanges allow them to even be used with highly viscous, crystallizing and contaminated fluids since their design has no dead spaces (inaccessible areas such as nooks and crannies) that allow the build-up of deposits. Diaphragm pressure gauges are used in many applications in the food and beverage industry as well as in engineering applications, plants, machinery and other equipment.

Designs:

Nominal Sizes: Housing diameter 100, 160 or 250 mm

Materials:

PMP04.x.A: Housing of stainless steel 1.4301, top and bottom flange of aluminum, measuring element of stainless steel 1.4571, connection of brass





PMP04.x.M: Housing of stainless steel 1.4301, top flange of aluminum, bottom flange of stainless steel 1.4571, connection of stainless steel 1.4571

PMP04.x.E: Housing of stainless steel 1.4301 top and bottom flange of stainless steel 1.4571, measuring element, connection of stainless steel

Process

connection: G 1/2 (standard) flange connection DN25, DN50, DN64, ANSI

Measuring Ranges:

Measuring range (mbar)	Order code			
				
for all nominal sizes				
-1200...0	P17	S17	T17	V17
0...10	P58	-	-	-
0...16	P59	-	-	-
0...25	P60	-	-	-
0...40	P61	-	T61	V61
0...60	P62	-	T62	V62
0...100	P63	-	T63	V63
0...160	P64	-	T64	V64
0...250	P65	-	T65	V65
0...400	P66	-	T66	V66
bar				
-1...0	P16	S16	T18	V18
-0,6...+1,0	P18	S18	T19	V19
-1...+0,6	P42	S42	T42	V42
-1...+1,5	P43	S43	T43	V43
-1...+3	P44	S44	T44	V44
-1...+5	P45	S45	T45	V45
-1...+9	P46	S46	T46	V46
-1...+15	P49	S49	T49	V49
-1...+25	P52	S52	T52	V52
0...0,6	P67	S67	T67	V67
0...1	P69	S69	T69	V69
0...1,6	P70	S70	T70	V70
0...2,5	P72	S72	T72	V72
0...4	P73	S73	T73	V73
0...6	P74	S74	T74	V74
0...10	P75	S75	T75	V75
0...16	P76	S76	T76	V76
0...25	P78	S78	T78	V78
0...40	P79	S79	T79	V79

Model Coding:

Order number: PMP04. 10. A. 1. P67. 0

Diaphragm Pressure Gauge

Design:

10 = 100 mm
16 = 160 mm
25 = 250 mm

Materials:

A = Top and bottom flange of aluminum, brass connection
M = Top flange of aluminum, bottom flange of VA, connection of VA
E = Top and bottom flange of VA, connection of VA (VA = vanadium stainless steel)

Process connection:

1 = G 1/2, design P
2 = Connecting flange DN25, design V
3 = Connecting flange DN50, design T
4 = Connecting flange DN64, design S
S = ANSI B16.5 150 / 300 lb./sq. in. (upon request)

Measuring range:

P17 to V79 = see "Measuring Ranges" table

Options and accessories (more than one may be selected)

0 = None

xx = see "Options and Accessories" table

Technical Details:

Housing: Round gauge housing of stainless steel, d = 100, 160, 250 mm
Protection type: IP45

Vibration dampening: optional with glycerin-filled gauge

Measuring element: diaphragm of stainless steel 1.4571

Pointer element:

PMP04.x.A: base and cover plate of brass, moving parts of nickel silver
PMP04.x.M: base and cover plate of brass, moving parts of nickel silver
PMP04.x.E: stainless steel 1.4571 / 1.4301

Dial face:

white aluminum, black characters to EN 837-3

Viewing window:

PMP04.x.A: Instrument glass
PMP04.x.M: Multilayer safety glass
PMP04.x.E: Multilayer safety glass

Accuracy:

Class 1.6

Maximum liquid temperature:

100 °C

Overload protection: 5.0 times full scale value, maximum 40 bar

Dimensions:

Measurement:	Dimensions in mm NG100, NG160, NG250 G 1/2 / 10 - 400 mbar/ 0.6 to 40 bar
b	50 / 50 / 55
c	15 / 14.5 / 16
D	100.8 / 161.3 / 251
G	G 1/2
h	129.5 / 168 / 209
d1	160 / 100
SW	27
Weight without glycerin filling	1.1 / 1.6 / 2.8 Kg
Weight with glycerin filling	1.4 / 2.5 / 5.0 Kg

Measurement:	Dimensions in mm NG100, NG160, NG250 DN64 / 0.6 - 40 bar
D	100.8 / 161.3 / 251
d1	100
d2	82
d3	75
e	1
f	19
G	M8
h	103.5 / 142 / 183
Weight without glycerin filling	1.3 / 1.8 / 3.0 Kg
Weight with glycerin filling	1.6 / 2.7 / 5.2 Kg

Options and Accessories:

Description	Code	for model PMP04
PTFE lined	PE	all models
Measuring system excess pressure protection 10 times, maximum 40 bar	U	all models
Measuring system vacuum protection , - 1 bar	A	all models
Measuring range > / = 0.6 bar		
Measuring range < 0.6 bar		
Indicator with fine graduations and knife edge pointer	ZF	all models
Double-scale dial (e.g. bar/psi)	SD	all models
Pointer element CrNi carbon steel	ZC	all models
Multiple-scale	SM	all models
Measuring system with venting/flushing valve	SH	all models
Print plate for creating specific, custom scale (single color or multicolored)	SS1 SSx	all models
Measuring system free of oil and grease for use for oxygen	MO	all models
Measuring system free of silicone	MS	all models
Glycerin-filled, measuring range < 0.6 bar	FG	all models
> / = 0.6 bar	FK	
Throttling screw in connection, d = 0.8 or 0.3 mm	D08 D03	all models
Process connection 1/2 NPT	Px	all models
Connection shank bored out to 8 mm	AG8	all models
Connection shank bored out to 12 mm	AG12	all models
Maximum temperature of fluid: 200 °C	MB	all models
Red graduations on dial face	MR	all models
Red gliding mark pointer in the viewing window	ZR	all models
Maximum indicator, can be reset, 1 time or 2 time	ZS1 ZS2	all models
Red gliding mark pointer on the dial face	ZR1	all models
Can be calibrated as per calibration regulations	E	all models
Test log	P	all models

Designs:

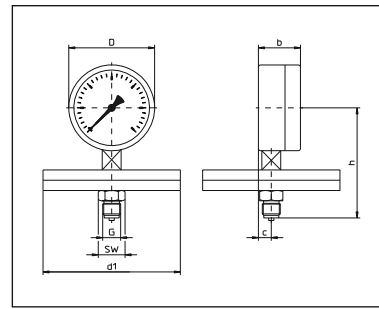

Design P:
10 to 400 mbar

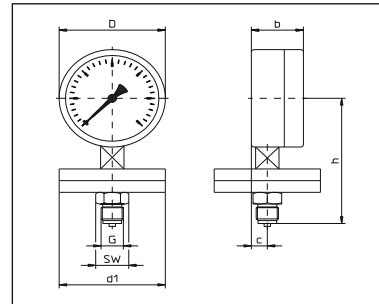

Design P:
0.6 to 40 bar

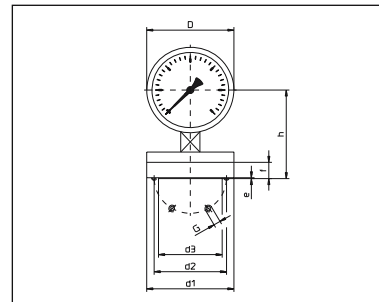

Design S:
0.6 to 40 bar

Dimensions:

Measurement:	Dimensions in mm NG100 / NG160/ NG250 DN50 / 40 - 400 mbar
D	100.8 / 161.3 / 251
d1	165
d2	125
d3	102
e	3
f	20
h	141 / 179.5 / 220.5
k	18
Weight without glycerin filling	5.0 / 5.5 / 6.7 Kg
Weight with glycerin filling	5.3 / 6.4 / 8.9 Kg

Measurement:	Dimensions in mm NG100 / NG160/ NG250 DN 50/ 0.6 - 40 bar
D	100.8 / 161.3 / 251
d1	165
d2	125
d3	-
e	-
f	20
h	104.5 / 143 / 184
k	18
Weight without glycerin filling	2.7 / 3.2 / 4.4 Kg
Weight with glycerin filling	3.0 / 4.2 / 5.6 Kg

Measurement:	Dimensions in mm NG100 / NG160/ NG250 DN25 / 40 - 400 mbar
D	100.8 / 161.3 / 251
d1	115
d2	85
d3	68
e	2
f	18
h	133 / 171.5 / 212.5
k	18
Weight without glycerin filling	3.2 / 5.3 / 6.8 Kg
Weight with glycerin filling	3.5 / 6.2 / 8.0 Kg

Measurement:	Dimensions in mm NG100 / NG160/ NG250 DN 25/ 0.6 - 40 bar
D	100.8 / 161.3 / 251
d1	115
d2	85
d3	68
e	2
f	25
h	109.5 / 148 / 189
k	-
Weight without glycerin filling	2.9 / 3.4 / 4.6 Kg
Weight with glycerin filling	3.1 / 4.3 / 5.7 Kg

Designs:

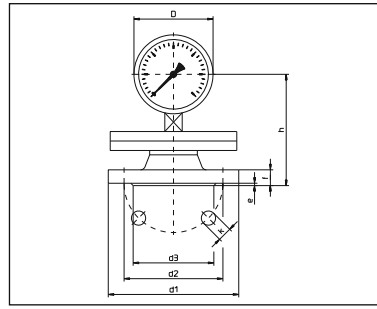

Design T:
40 to 400 mbar

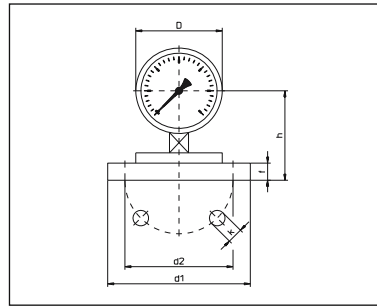

Design T:
0.6 to 40 bar

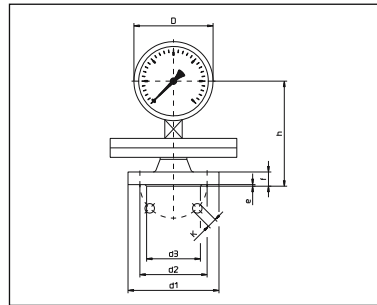

Design V:
40 to 400 mbar

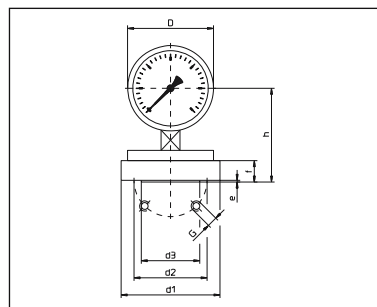

Design V:
0.6 to 40 bar