



PKP Prozessmesstechnik GmbH

Borsigstrasse 24

D-65205 Wiesbaden-Nordenstadt

Tel: 06122 / 7055 - 0

Fax: 06122 / 7055 – 50

Operating Instructions

DTL08

Compact Calorimetric Air Flow Sensor

Airflow Sensor
Manual
Airflow sensor/Volume flow sensor
DTL08

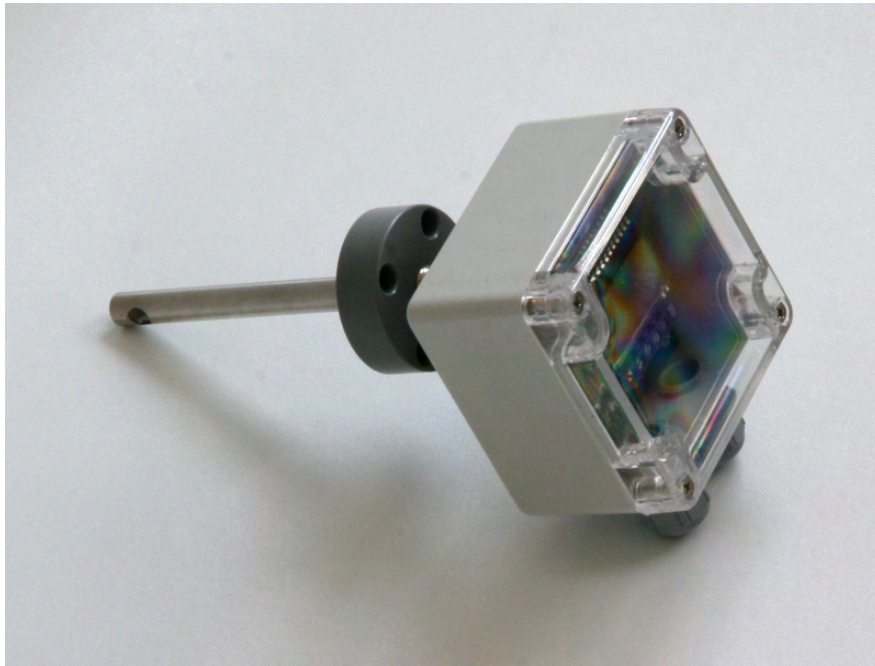

Our products correspond to the requirements of the European guidelines.
WEE Electrical of 01.08.2005 and electronics of old devices 2002/96/EG RoHS 2002/95/EG of
01.07.2006.



The RLWS8AL V2 is a micro controller based airflow monitor which watches gaseous flows from 0.5m/s to 10/30m/s. It provides a 4-20mA as well as a 0-10V-DC output. Also it provides a 0-10V-DC output based on the temperature.

Technical Data:

Type	DTL08
supply voltage	24VDC
supply voltage tolerance	+5%
surge category	II
supply voltage signal	green LED
power consumption	4AV
ambient temperature	-20..+60°C
flow voltage output	0..10V (Ra=10kOhm), linear
flow current output	4..20mA (Ra=0.2kOhm), linear
flow temperature output	0..10V (Ra=10kOhm), linear
measurement error	+5% of measuerment range
relays output, clamp 8+9	N/C contact, opens at flow
function at flow	switch point set with potentiometer
transistor output	open collector, isolator at flow
reproduceability of measurement values	+2%
media temperature	-25..80°C
temperature gradient	30K/min
switch point	set by potentiometer
measurement range standard	0.1 .. 10m/s
measurement range max	0.1 .. 30m/s
volume flow max	49100m³/h
volume flow max	49100l/min
sensor type	mounted
immersion deptch*	approx. 130mm
process connection	M16x1.5; flange
sensor material	Brass,nickel plated
pressure resistance	10bar
protection class, case	IP65
protection class, sensor	IP54 (with NTC IP68)
pollution class	II
electrical connection	9/10 clamp, max 1.5mm²
case dimensions about	L=56mm; W=86mm; H=82mm
compliance	-
Accessory	Mounting flange

Reference terms and conditions: straight pipe run (upstream) > 10xDN, straight pipe run (downstream) > 5DN laminar flow: at 0°C and 1.013bar.

Installation:

To avoid malfunction please observe the following:

- the sensors tip needs to be mounted in the middle of the duct
- the sensor elements must be immersed completely into the medium. The flow must be laminar.
- install the sensor so that the mark points exactly upstream
- in vertical tube the flow directions should be upwards
- maintain 10xD of straight pipe run upstream and 5xD downstream

Attention:

Condensation and dirt may change the measurement result! The sensor must not be disconnected before or within operating!

Cleaning of the sensor:

The DTL08 contains a sensor element which is sensitive to mechanical loading and which must not be touched with hard and pointed objects. Any cleaning that may be necessary is possible in water (also with addition of detergents). Let the unit drip off and dry before reinstallation.

Electrical connection:

<u>1</u>	<u>2</u>	<u>3</u>	<u>4</u>	<u>5</u>	<u>6</u>	<u>7</u>	<u>8</u>	<u>9</u>	<u>10</u>
24V DC	10V Temp		-20mA Flow		Alarm OC		Relay		
Ground	Ground	10V Flow	+20mA Flow		Relay		Relay		not connected

Dimensions: depth of box about 86mm

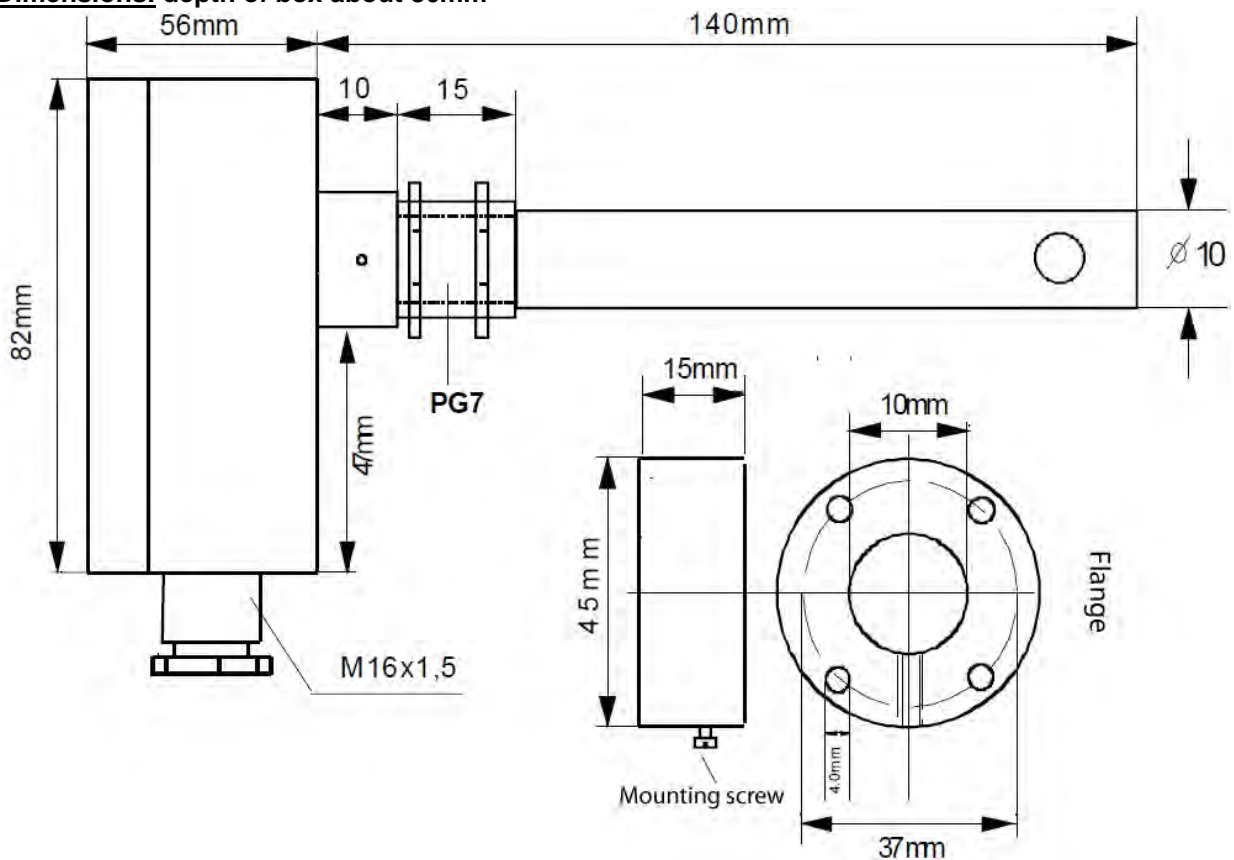

Intended usage:

The DTL08 is to be used for monitoring of gaseous media at flows/volumes within its provided technical characteristics. Its application areas are e.g. climate- and cooling installations, machines and equipments for filter monitoring, monitoring in clean rooms, monitoring of supply air (heating register), monitoring of volume flows,...

Setting up a DTL08:

The LED-chain shows the actual flow relatively to the maximum flow (e.g.: max. flow=10m/s, 3 LEDs enlightend, means 30% respectively 3m/s). If the most right LED blinks the flow is above the maximum flow. The switch point is set by the potentiometer. The set switch point is shown by a blinking LED in the LED-chain.

Signal outputs:

The output relays provides an N/C switch function. The switch point of the transistor output is set according to the realy switch point.

Following analogue outputs are provided as well:

output	dependence
0..10VDC	temperature
0..10VDC	flow
4..20mA	flow

Process connection:

PG7

M16x1,5 to PG7

G 1/2" to PG7

flange²

²only avaiable with 80°C-version!

What to do if flow monitor does not operate properly:

Problem	Cause	Sollution
green LED off	wrong or wrongly connected suply voltage	check supply voltage
no recognition of flow	wrong or wrongly installed sensor	check sensor installation and sensor number
sensor shows abnormal sensitivity	sensor is polluted	clean sensor (refer to "cleaning the sensor"!)

DTL08

Compact calorimetric mass flow sensor for air

- **Current and voltage outputs for mass flow rate**
- **Limit switch**
- **Additional analog output for temperature**
- **Causes negligible pressure drop**
- **No moving parts**
- **Unaffected by duct diameter, pressure and temperature**



Description:

Model DTL08 mass air flow sensors function according to the proven-reliable calorimetric principle. The sensor tip contains a resistor which is electronically heated. The air flowing around the sensor tip removes heat from it, thus changing its electrical resistance value. A second, unheated resistor detects the air temperature. The temperature difference between both resistors is proportional to the flow rate and thus to the flow volume. Model DTL08 mass air flow sensors are microprocessor based and come standard with linear analog outputs for flow rate and temperature as well as a limit contact.

Typical Applications:

Model DTL08 mass air flow sensors are economical, high-performance units. These devices are used in applications where the flow of straight, non-turbulent air streams has to be measured or monitored. Such applications include the following: HVAC, air-supply systems, air-compressor monitoring, air-consumption measurement, leak monitoring, cooling circuits, and the like.

Models:

DTL08.ALS ...: Linear analog output for air flow
Linear analog output for temperature
Switch output for flow

Dimensions:

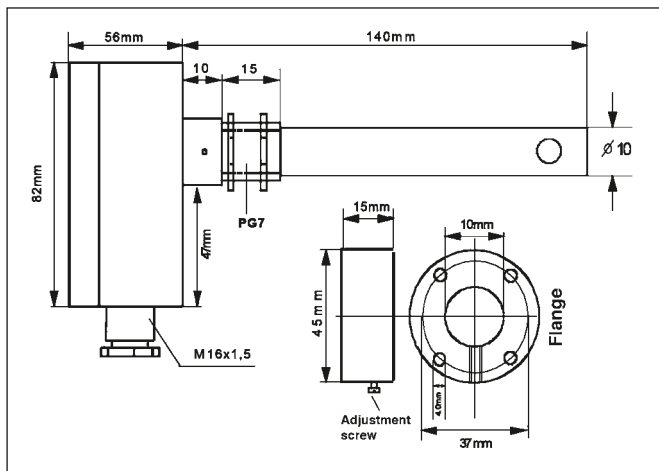

Electrical connection:

10 pin terminal strip:

Pin	assignments
1	+24 VDC
2	Ground
3	0–10 V analog output air temperature (+)
4	0–10 V analog output air flow stream (+)
5	4–20 mA analog output air flow stream (–)
6	4–20 mA analog output air flow stream (+)
7	Transistor output (O/C signal)
8	Relay output (normally closed (N/C))
9	Relay output (normally closed (N/C))
10	Not assigned

Model Coding:

Order Number: DTL08. ALS. 30. 1. 0

Calorimetric mass air flow sensor

Models:

ALS = Analog outputs for flow and temperature, limit contact

Measuring range:

01 = 0–1 m/s
08 = 0–8 m/s
16 = 0–16 m/s
30 = 0–30 m/s

Process connection

1 = PG7 conduit thread (7 mm)
2 = Mounting flange
3 = M16 x 1.5 male thread (with adapter)
4 = G 1/2 male thread (with adapter)

Options:

0 = none
9 = please specify in writing

Technical Specifications:

	DTL08.ALS
Measuring range	0–1 m/s, 0–8 m/s, 0–16 m/s, 0–30 m/s
Analog output: flow	4–20 mA (Ra = 200 Ohm) 0–10 V (Ra = 10 kOhm)
Analog output: temp.	0–10 V (Ra = 10 kOhm)
Switch output	Relay 200 VDC, 1 A, normally closed (N/C), Transistor output (O/C signal), non-conductive during flow
Accuracy¹⁾	± 5 % of measured range end value
Reproducibility¹⁾	± 2 %
Temperature gradient	30 K/min
Power supply:	24 VDC ± 5 %
Power consumption max.	4 VA
Temperature range:	Ambient: –20–+60 °C medium: –25–+80 °C
Sensor:	Max. pressure: 10 bar Material: Brass, nickel-plated Insertion depth: 130 mm (other sensor lengths on request) Diameter: 10 mm Process connection: PG7 conduit thread (7 mm, standard) Mounting flange; Adapter M16 x 1.5 or 1/2" male thread
Electrical protection:	meter housing: IP 65 sensor: IP 54
Electronics housing:	Material: Plastic Dimensions: L x W x H = 56 x 84 x 82 mm

¹⁾ Reference conditions: inlet pipe section > 10 x DN, outlet pipe section > 5 x DN, laminar, non-turbulent flow, air at standard conditions: 0 °C and 1.013 bar

PKP Prozessmesstechnik GmbH

Borsigstraße 24 · D-65205 Wiesbaden
+49 (0) 6122-7055-0 · +49 (0) 6122-7055-50
Email: info@pkp.de · Internet: www.pkp.de



PKP Process Instruments Inc.

10 Brent Drive · Hudson, MA 01749
+1-978-212-0006 · +1-978-568-0060
Email: info@pkp.eu · Internet: www.pkp.eu

