



*PKP Prozessmesstechnik GmbH*

*Borsigstrasse 24*

*D-65205 Wiesbaden-Nordenstadt*

*Tel: 06122 / 7055 - 0*

*Fax: 06122 / 7055 – 50*

## **Operating Instructions**

### **DS10**

*Float-type flow meter with glass measuring tube*

## ***Contents***

---

|  |   |
|--|---|
| 1 Introduction                                   | 2 |
| 2 Safety Information                             | 2 |
| 3 Description of Functions                       | 3 |
| 4 Set-up and Adjustment                          | 3 |
| 5 Limit Value Signal Sensors                     | 3 |
| 6 Maintenance and Care                           | 4 |
| 7 Specifications: See data sheet in the appendix |   |

## ***1 Introduction***

---

Series DS10 float-type flow meters are noted for their reliable function and easy operation. To obtain the greatest benefit from this device, please observe the following cautionary statement:

**Persons who are responsible for setting up or operating this device must be sure to read and understand the operating instructions and the safety information pertaining to it.**

## ***2 Safety Information***

---

### ***2.1 General Instructions***

To ensure safe operation, the device must only be operated according to the information in the operating instructions. When the device is in use, the regulations and safety standards applicable to the specific application must also be observed. This statement also applies to the use of accessories.

### ***2.2 Proper Usage***

Series DS10 float-type flow meters are designed to monitor continuous flow rates of liquids or gases. Any application extending beyond this specific intended use does not constitute proper usage. Unless indicated otherwise, the scales on these devices are based on air at 1.2 bar absolute pressure at 20°C or on water. Special applications in which shock-type loads are encountered (e.g. cyclic operation) should first be discussed with and examined by our engineering department.

Series DS10 float-type flow meters must not be employed as the sole means of avoiding hazardous conditions in machinery and installations.

The machinery and installations must be designed in such a manner that faulty conditions and malfunctions will not present hazardous situations for operating personnel.

### ***2.3 Qualified Personnel***

Series DS10 float-type flow meters must only be used by qualified, knowledgeable personnel trained in correct use of these devices. Qualified personnel are those persons familiar with setting up and assembling these devices, placing them in service and operating them. In addition, such personnel must also be qualified to perform the work associated with the application for which the device is being used.

## ***3 Functional Description***

---

The float-type flow meter must be installed in a vertical position. The flow must proceed in the direction from the low end to the high end of the scale.

This measuring device must be connected with fittings compatible with its design. When connecting the device, be sure that the pipes are run stress-free and aligned so that they are centered with the connection ports on the device. If necessary, support the pipes to prevent the transmission of vibrations to the device.

## ***4 Set-up and Adjustment***

---

The actual operating pressure and temperature in the installation must not exceed the maximum values indicated in the specifications.

1. Close the needle valve on the flow meter.
2. Open the shut-off valves upstream and downstream of the flow meter.
3. For liquids, be sure to carefully bleed the air out of the piping. For gases, allow the operating pressure to slowly increase. Avoid hammering or pulsing (risk of glass breakage).
4. Open the needle valve and set the desired flow rate.
5. The flow rate is read at the upper edge of the float.

Should the operating parameters deviate from the calibration data (flow range, flowing medium, pressure, density and temperature), the flow rate displayed can be converted as per VDI / VDE - Guideline 3513.

## ***5 Limit Value Signal Sensors***

---

To signal defined flow rates, the DS10 flow meter can be fitted with limit value signal sensors that trigger an electrical signal when the set value is reached. Each limit value to be monitored requires a separate signal sensor.

Limit value signal sensors can only be used in devices with stainless steel floats. The limit value signal sensors are inductive ring sensors that are slipped over the glass cone of the DS10. When the metallic float passes through the ring sensor, an electrical signal is triggered. Monostable limit switches function as pulse contacts; bistable limit switches detect the direction of motion of the float.

This provides clear, definite information on the location of the float with respect to the ring sensor (above or below).

Limit switches with two-wire connections have electrical characteristic values as per DIN EN 50227 (NAMUR wiring recommendations).

Their use requires an isolating switch amplifier.

Limit switches with three-wire connections can be used without an isolating switch amplifier; they can be directly connected to switched inputs at controllers.

When connecting the limit value signal sensor, a terminal box with a metric conduit thread adapter can be fitted to the flow meter.

When using bi-stable limit switches an EMC filter is installed in the terminal box.

## ***6 Maintenance and Care***

---

Due to the small number of moving parts, these devices require minimal maintenance. Nevertheless, regular performance tests and maintenance will not only increase the service life and functional safety of the device but also those of the entire installation.

The frequency of maintenance depends on the following:

- The contamination of the medium
- Ambient conditions (e.g. vibrations)

When performing maintenance, be sure to check for the following:

- Proper function of the switching contact (on devices with limit value signal sensors)
- Leakage at the device
- Free movement of the float

The user is responsible for setting suitable maintenance intervals for the specific application.

Maintenance Notes:

- The free movement of the float can be checked by changing the flow rate and observing the float.
- In most cases, cleaning the device will only require rinsing it with clean liquid. In stubborn cases (e.g. lime deposits), standard, commercially available cleaners can be used as long as their ingredients will not attack the materials used in the device.

### ***6.1 Replacing the Measuring Tube:***

**Caution:** To avoid glass breakage, the measuring tube must be installed centered between the seals.

1. Close the valves upstream and downstream of the device to prevent escape of the medium being measured.
2. Close the needle valve at the device.
3. Slide the Plexiglas protective cover upward and then remove it toward the front.
4. To release the measuring tube, turn the retainer in the base of the device counter-clockwise. The tube can now be removed.

To reinstall the tube, follow the above instructions in reverse order.

# DS10

## Variable Area Flowmeter For Low Flows With Glass Measuring Tube

- for liquids and gases
- body brass or st. steel
- with integrated needle valve
- limit switch optionally
- accuracy class 2.5 or 4.0

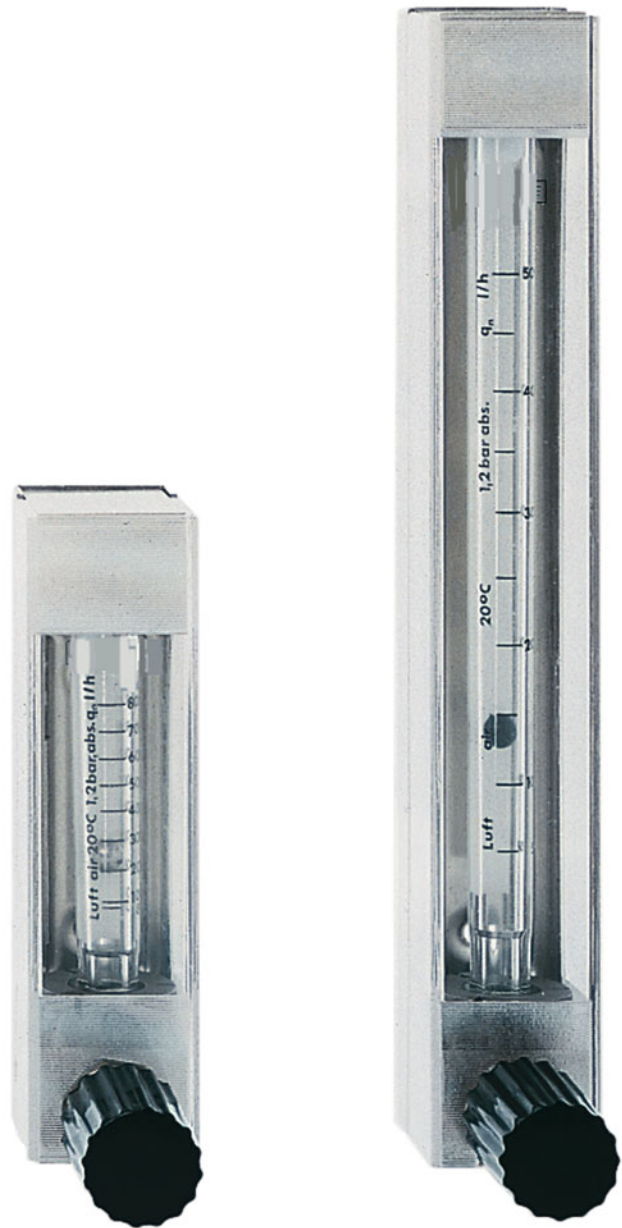

### Description:

The flowmeters DS10 operate according to the proven variable area principle. The flowing media moves a float upwards against gravity in a conical measuring tube. The height of the float indicates the flow rate and may be read off a burnt-in scale on the measuring tube. Optional inductiv contacts, which are mounted on the measuring tube, may be used for flow rate limit detection. All meters are equipped with an integrated needle valve for exactly regulating the flow rate.

### Applications:

Variable area flowmeters model DS10 are mainly used for measuring and monitoring the flow rate of low- viscous liquid and gaseous media. Scales for water or air at standard operating conditions have already been defined. For other media or different process conditions special scales are available.

## Versions:

**DS10.1:** Miniature version, height 111 mm  
accuracy class 4

**DS10.2:** Standard version, height 146 mm  
accuracy class 2,5

## Ranges:

| Range no. | Range<br>NI/h air, 20°C,<br>1.2 bar abs. | Contact-<br>version | DS10.1<br>Miniature | DS10.2<br>Standard |
|-----------|--|---------------------|---------------------|--------------------|
| 01        | 0,5...5                                  | A                   | x                   | x                  |
| 02        | 0,8...8                                  | A                   | x                   | x                  |
| 03        | 1,6...16                                 | A                   | x                   | x                  |
| 04        | 4...40                                   | A                   | x                   | x                  |
| 05        | 6...60                                   | A                   | x                   | x                  |
| 06        | 10...100                                 | B                   | x                   | x                  |
| 07        | 25...250                                 | B                   | x                   | x                  |
| 08        | 50...500                                 | B                   | x                   | x                  |
| 09        | 80...800                                 | B                   | x                   | x                  |
| 10        | 100...1000                               | B                   | -                   | x                  |
| 11        | 180...1800                               | B                   | -                   | x                  |
| 12        | 240...2400                               | B                   | -                   | x                  |
| 13        | 300...3000                               | B (min.)            | -                   | x                  |
| 14A       | 400...4000                               | B (min.)            | -                   | x                  |
| 15A       | 500...5000                               | B (min.)            | -                   | x                  |
|           | <b>l/h water</b>                         |                     |                     |                    |
| 16        | 0,25...2,5                               | A                   | x                   | x                  |
| 17        | 0,5...5                                  | B                   | x                   | x                  |
| 18        | 1,2...12                                 | B                   | x                   | x                  |
| 19        | 2,5...25                                 | B                   | x                   | x                  |
| 20        | 4...40                                   | B                   | x                   | x                  |
| 21        | 6...60                                   | B                   | x                   | x                  |
| 22        | 10...100                                 | B (min.)            | x                   | x                  |
| 23        | 12...120                                 | B (min.)            | x                   | x                  |
| 24        | 16...160                                 | B (min.)            | x                   | x                  |

x = available - = unavailable

**Contacts:** The contact version is defined by the measuring range.  
(min.) = Contact only available for minimum monitoring

## Dimensions:

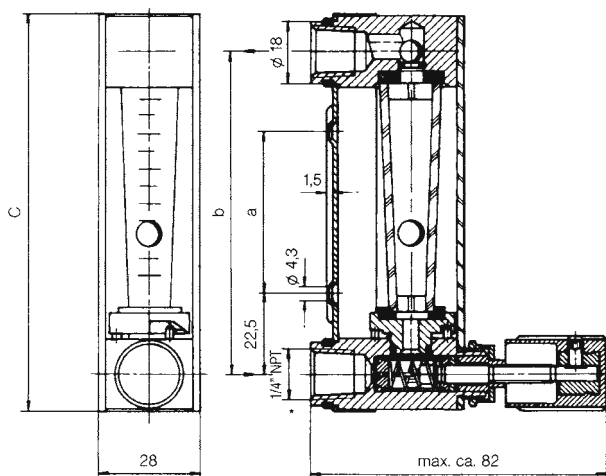

| Version | a (mm) | b (mm) | c (mm) |
|---------|--------|--------|--------|
| DS10.1  | 45     | 90     | 111    |
| DS10.2  | 80     | 125    | 146    |

## Ordering code:

**Order no:** DS10. 2. 2. 1. 1. 06. 1. 1. 0

**Variable area flowmeter  
with glass measuring tube**

### Version

1 = Miniature  
2 = Standard

### Process connection

1 = G 1/4 female on back  
2 = 1/4" NPT on back

### Material

1 = brass  
2 = st. steel

### O-rings

1 = Viton (standard)  
2 = PTFE / FFKM

### Ranges

01...24 = according to table  
99 = special range

### Valve

0 = without  
1 = valve on inlet side (Standard)  
2 = valve on outlet side

### Limit switch

0 = without  
1 = 1 contact (version A)  
2 = 2 contacts (version A)  
3 = 1 contact (version B)  
4 = 2 contacts (version B)

### Options (multiple selection possible)

0 = without  
1 = panel mounting set  
2 = cable connector housing  
for meters with contact

Special process connections (hose connectors, SWAGELOK, ERMETO or others) on request.

For operation of the limit switches transmitter relays model KFA...SR2-Ex1.W for 1 contact or KFA...SR2-Ex2.W for 2 contacts are available. Technical specifications and prices on request.

## Technical Specifications:

**max. pressure:** 10 bar

**max. temperatur:** 100 °C (80 °C with contact)

**materials:** Armature and valve brass or st. steel,  
float st. steel, O-rings Viton or PTFE /  
FFKM, glass Borosilikate

**Accuracy class:** DS10.1: Klasse 4  
DS10.2: Klasse 2,5

**PKP Prozessmesstechnik GmbH**

Borsigstraße 24 · D-65205 Wiesbaden  
+49 (0) 6122-7055-0 · +49 (0) 6122-7055-50  
Email: info@pkp.de · Internet: www.pkp.de

**PKP Process Instruments Inc.**

10 Brent Drive · Hudson, MA 01749  
+1-978-212-0006 · +1-978-568-0060  
Email: info@pkp.eu · Internet: www.pkp.eu

