



*PKP Process Instruments Inc.*

*10 Brent Drive*

*Hudson, MA 01749*

*Tel: +1-978-212-0006*

*Fax: +1-978-568-0060*

*PKP Prozessmesstechnik GmbH*

*Borsigstrasse 24*

*D-65205 Wiesbaden-Nordenstadt*

*Tel: 06122 / 7055 - 0*

*Fax: 06122 / 7055 - 50*

## **Operating Instructions**

### **DB41**

*Thermal mass flowmeter and counter for gasses*

	Page
Safety instructions	3
Instruments description	4
Installation description	4
Technical data	5
Pulse signals/pulse lengths	6
Measuring ranges	6
Drawing of the instrument/instruments dimensions	7-9
Service information	10
Display functions	11-12
Warranty	13
Ordering data	13

---

**Please read carefully before starting the device!**



Warning: Do not exceed the pressure range of 16 bar!

Observe the measuring range of the sensor!

Always observe the direction of flow when positioning the sensor!

The screwed fixture must be pressure tight.

It is absolutely necessary to avoid condensation on the sensor element or water drops in the measuring air as they may cause faulty measuring results.

The manufacturer cannot be held liable for any damage which occurs as a result of non-observance or non-compliance with these instructions. Should the device be tampered with in any manner other than a procedure which is described and specified in the manual, the warranty is cancelled and the manufacturer is exempt from liability.

The device is destined exclusively for the described application.

We offer no guarantee for the suitability for any other purpose and is not liable for errors which may have slipped into this operation manual. We are also not liable for consequential damage resulting from the delivery, capability or use of this device.

We offer you to take back the instruments of the instruments family VA 410 which you would like to dispose of.

Adjustments and calibrations should only be carried out by qualified employees from the measurement and control technology branch.

## INSTRUMENTS DESCRIPTION

---

The DB41 is a compact consumption counter for compressed air and gases.

### Special features:

- Optimum accuracy due to compact design
- Integrated in- and outlet section
- Less flow due to measuring section
- Indication of the current value in l/min, m<sup>3</sup>/h, m<sup>3</sup>/min, l/s, ft/min, cfm and of the counter in m<sup>3</sup> resp. l

### Programming via SFA software.

- Analogue output 4...20 mA scalable
- Switching of the units between m<sup>3</sup>/h, m<sup>3</sup>/min, ft/min, l/min, l/s, cfm, m/s
- Reading out the service data

## INSTALLATION DESCRIPTION

---

The following table shows the additionally required inlet and outlet sections depending on the existing flow

**Table of additionally required inlet and outlet sections**

Flow obstruction <b>in front of</b> the measuring section	Minimum length inlet section (L1)	Minimum length outlet section (L2)
2 90 ° bends on one level	<b>20 x D</b>	<b>5 x D</b>
2 90° bends 3-dimensional change of direction	<b>35 x D</b>	<b>5 x D</b>
Shut-off valve	<b>45 x D</b>	<b>5 x D</b>

The respective minimum values required are indicated here. If it is not possible to observe the stipulated equalising sections, considerable deviations in the measuring results must be expected.

<b>Measured variables:</b>	<b>l/min</b> <b>m<sup>3</sup>/h</b> (standard: DIN 1945, ISO 1217 bei 20°C and 1000 mbar) mass flow rate on request (kg/s, kg/min, kg/h)
<b>Principle of measurement:</b>	<b>calorimetric measurement</b>
<b>Sensor:</b>	<b>Pt45, Pt1000</b>
<b>Measuring medium:</b>	<b>air, gases</b>
<b>Operating temperature:</b>	<b>-30 ... 140°C probe tube</b> <b>-30 ... 80 °C housing</b>
<b>Operating pressure:</b>	<b>up to 16 bar</b>
<b>Analogue output:</b>	<b>4 ... 20 mA (please see table in the following)</b> <b>max. burden &lt; 500 Ohm</b>

order no	description	analogue output
DB41.08	VA 410 with integrated 1/4" meas. section	4... 20 mA = 0 ... 90 l/min
DB41.15	VA 410 with integrated 1/2" meas. section	4... 20 mA = 0 ... 80 m <sup>3</sup> /h
DB41.20	VA 410 with integrated 3/4" meas. section	4... 20 mA = 0 ... 140 m <sup>3</sup> /h
DB41.25	VA 410 with integrated 1" meas. section	4... 20 mA = 0 ... 240 m <sup>3</sup> /h
DB41.40	VA 410 with integrated 1 1/2" meas. section	4... 20 mA = 0 ... 400 m <sup>3</sup> /h

<b>Pulse output:</b>	<b>1 pulse per m<sup>3</sup> resp. l</b> (see pulse diagram on page 6),
<b>Power supply:</b>	<b>12 to 30 VDC smoothed ± 15%</b>
<b>Power input:</b>	<b>max. 80 mA at 24 VDC</b>
<b>Accuracy:</b>	<b>± 3% m. v.</b> <b>± 2% m. v.</b> (option via 5 point ISO precision calibration)
<b>Display:</b>	<b>Flow in m<sup>3</sup>/h (1/2" bis 1 1/2"), l/min (1/4")</b> <b>Counter in m<sup>3</sup> (1/2" bis 1 1/2"), resp. l (1/4")</b> <b>Measured values max. 6 digits, counter max. up to 99,999,999 l resp. m<sup>3</sup>, then drops back to 0</b>
<b>Units:</b>	<b>m<sup>3</sup>/h resp. l/min</b> (standard factory settings) Further units selectable via software: <b>m<sup>3</sup>/min, l/s, ft/min, cfm</b>
<b>Mounting thread:</b>	<b>1/4", 1/2", 3/4", 1", 1 1/2"</b>
<b>Material</b>	<b>Measuring section: Stainless steel 1,4301</b>

## PULSE SIGNALS/PULSE LENGTHS

### Pulse output signal indication

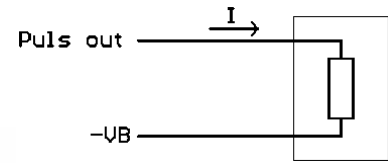
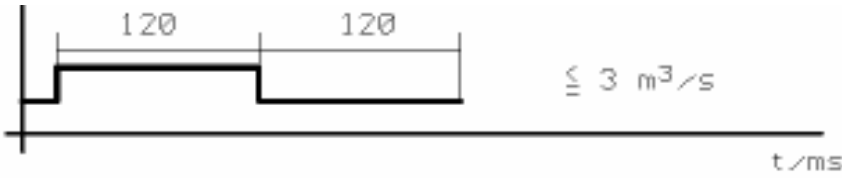

Pulse output:

max. voltage  
pulse +P = +VB (12 .. 30 VDC),  
active signal  
max. current I = 10 mA

### Internal pulse receiver:

The numbers of m<sup>3</sup> per second are summed up and indicated after one second.

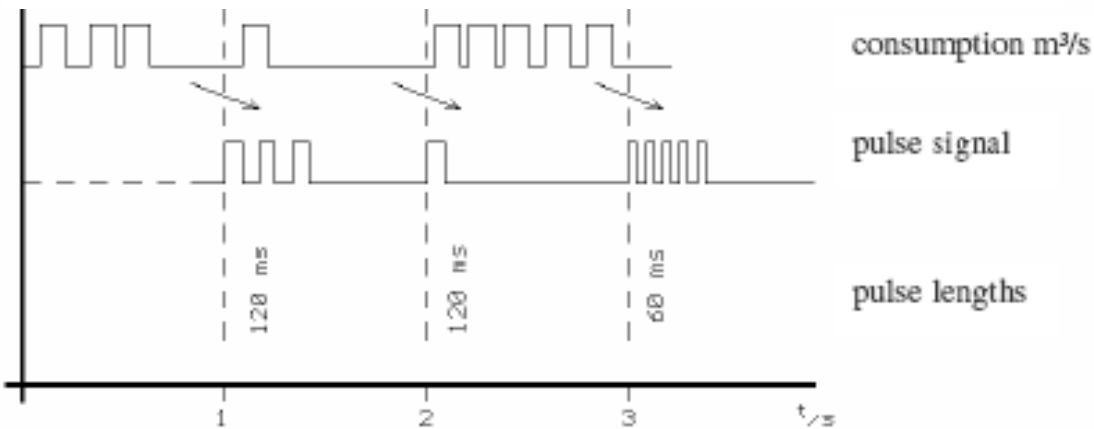

### Consumption-depending pulse lengths

flow [m <sup>3</sup> /sec]	pulse length [msec]	max. consumption [m <sup>3</sup> /min]	max. consumption [m <sup>3</sup> /h]
up to 3	120	180	10800
from 3	60	480	28800
from 8	30	960	57600

## MEASURING RANGES

### Flow measuring ranges

inner diameter			VA 410	Consumption
inch	mm		meas. ranges from...to	Standard setting
1/4"	8,8	DN 10	0.8 ... 90 l/min	l
1/2"	16.1	DN 15	0.2 ... 80 m <sup>3</sup> /h	m <sup>3</sup>
3/4"	21.7	DN 20	0.2 ... 140 m <sup>3</sup> /h	m <sup>3</sup>
1"	27.3	DN 25	0.2 ... 240 m <sup>3</sup> /h	m <sup>3</sup>
1 1/2"	41.8	DN 40	1.8 ... 400 m <sup>3</sup> /h	m <sup>3</sup>

**DRAWING OF THE INSTRUMENT/INSTRUMENTS DIMENSIONS**

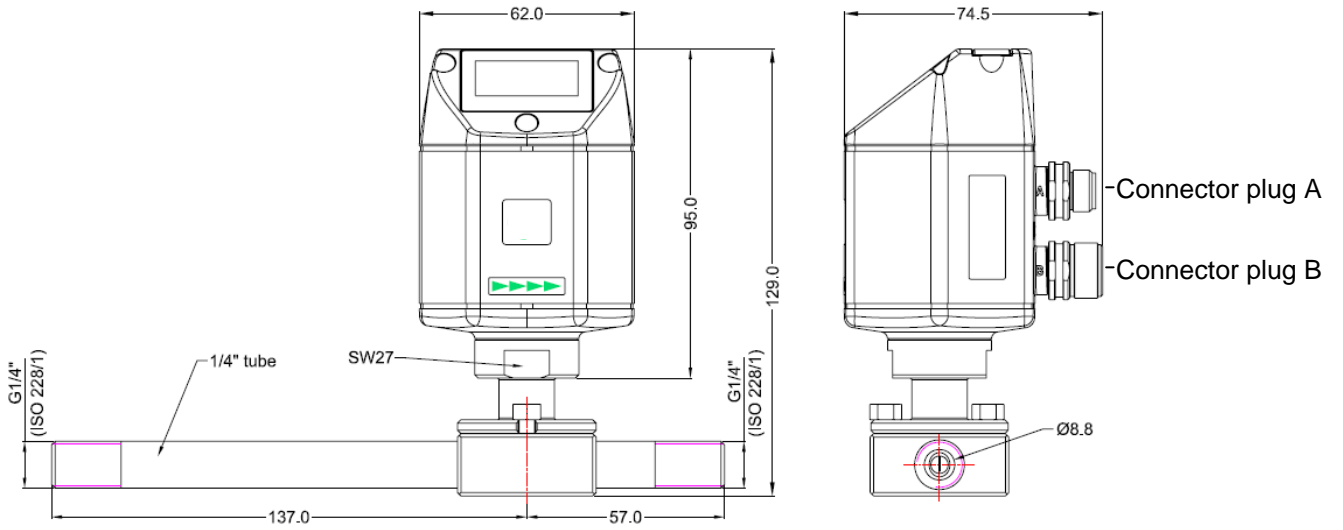

**DB41—1/4"**

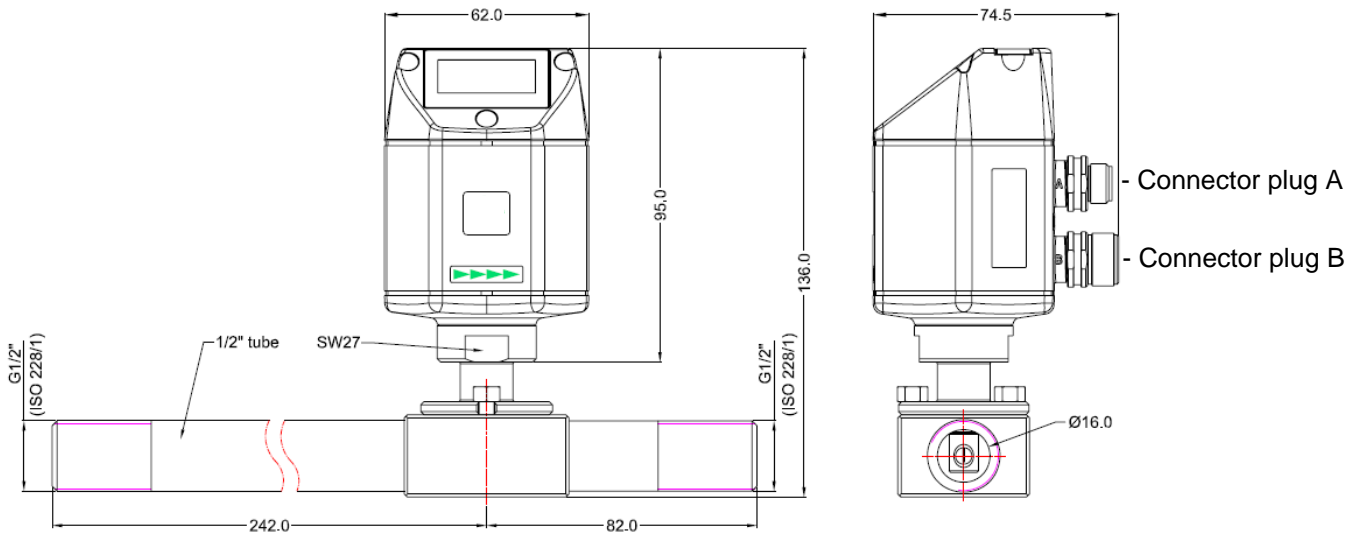

**DB41—1/2"**

**DRAWING OF THE INSTRUMENT/INSTRUMENTS DIMENSIONS**

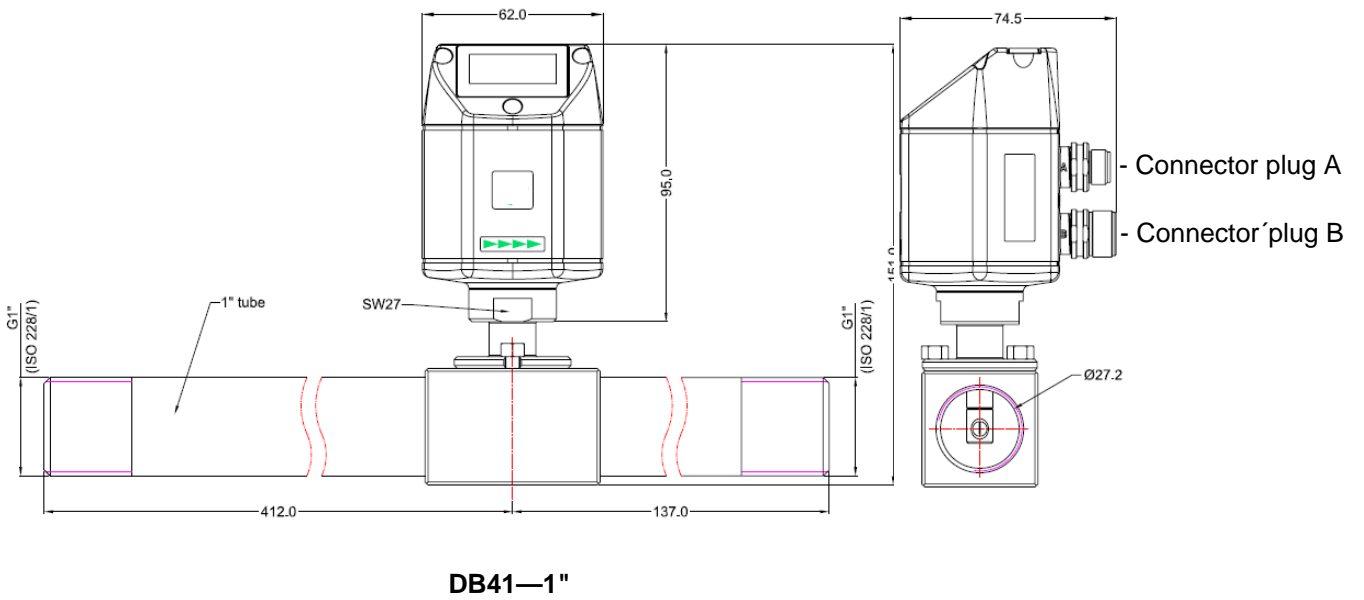
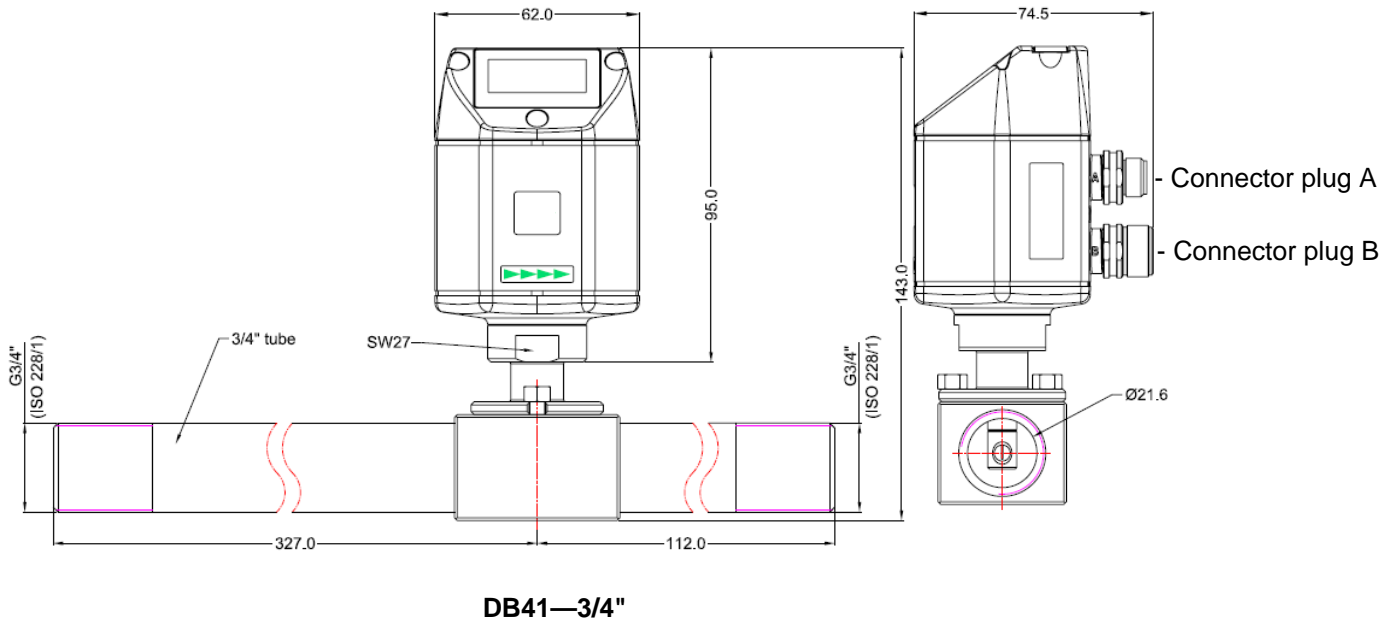

## DRAWING OF THE INSTRUMENT/INSTRUMENTS DIMENSIONS

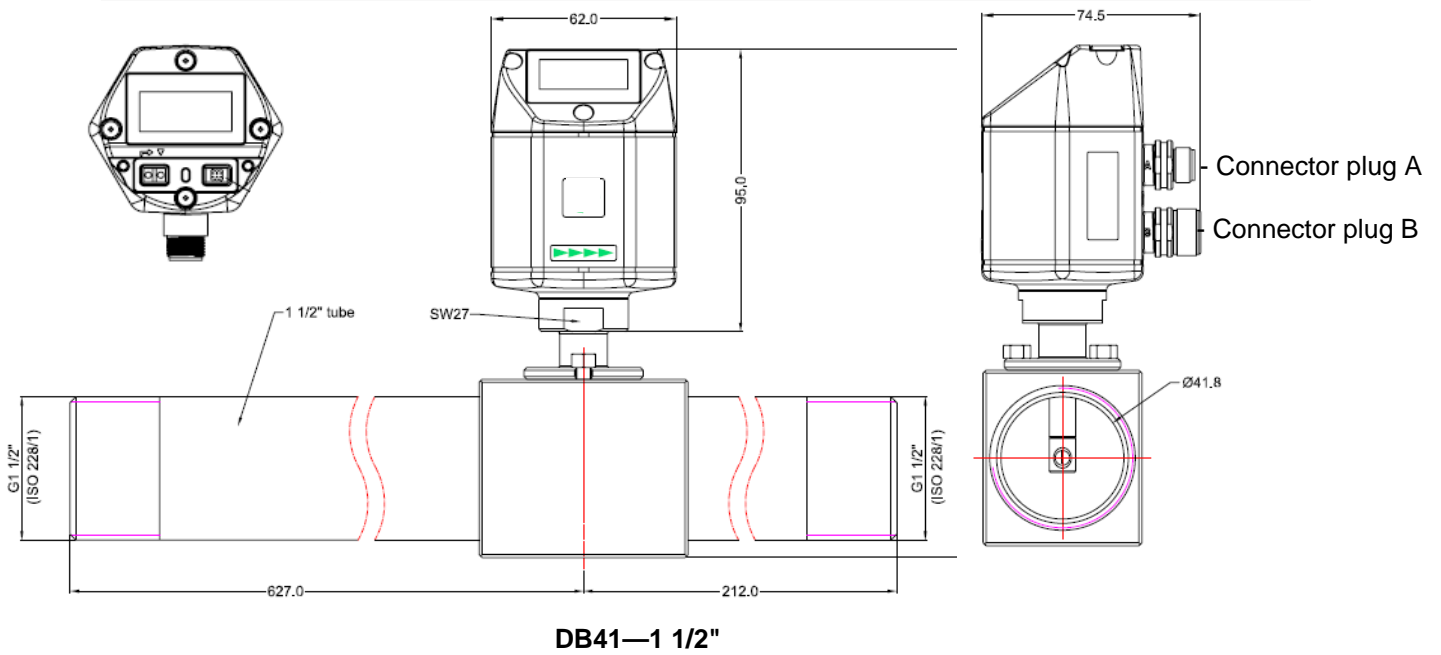

		Pin 1	Pin 2	Pin 3	Pin 4	Pin 5
DB41	<b>Connector A</b>	SDI	-VB	+VB	+I 4... 20 mA	+P Impuls
	<b>Connection cable A</b> 0554.0104 (5 m) 0554.0105 (10 m)	brown	white	blue	black	grey
	<b>Connector B*</b>	NC	NC	NC	NC	NC

SDI	Digital signal (internal data transfer)
-VB	Negative supply voltage 0 V
+VB	Positive supply voltage 12...30 VDC smoothed
+I	Positive 4...20 mA signal
+P Impuls	Pulse output +VB see page 7
NC	Not connected

**\* Connector plug B without any function! Just for internal use!**

### M12 connector plug

If no connection cable ( 0553 0104, 0553 0105 ) is ordered the sensor will be supplied with a M12 connector plug. the user can connect the supply and signal cables as indicated in the connection diagram.

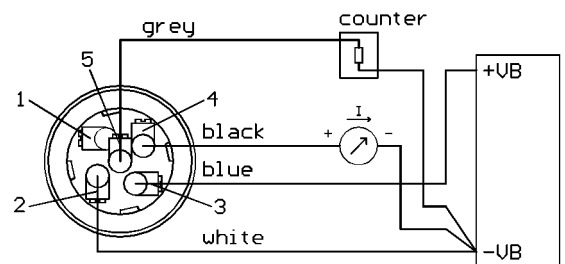
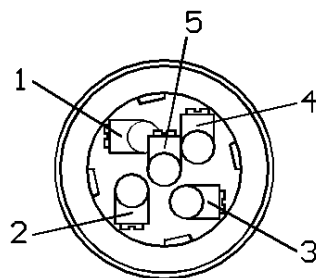

Connector plug

**Maintenance**

The sensor head should be checked regularly for dirt and cleaned if necessary. Should dirt, dust or oil accumulate on the sensor element, a deviation will occur in the measuring value. An annual check is recommended. Should the compressed air be heavily soiled this interval must be shortened.

**Cleaning of the sensor head**

The sensor head can be cleaned by carefully moving it to and fro in warm water with a small amount of washing-up liquid. Avoid physical intervention on the sensor (e. g. using a sponge or brush). If soiling cannot be removed, service and maintenance must be carried out by the manufacturer.

**Re-calibration**

If no customer specifications are given then we recommend to carry out calibration every 12 months. For this purpose the sensor must be sent to the manufacturer.

**Spare parts and repair**

For reasons of measuring accuracy spare parts are not available. If parts are faulty they must be sent to the supplier for repair.

If the measuring device is used in important company installations we recommend to keep a spare measuring system ready.

**Calibration certificates**

Calibration certificates are issued by the manufacturer on request. This is a fee-paying service. Precision is tested with PTB (German National Metrology Institute) volume flow nozzles.

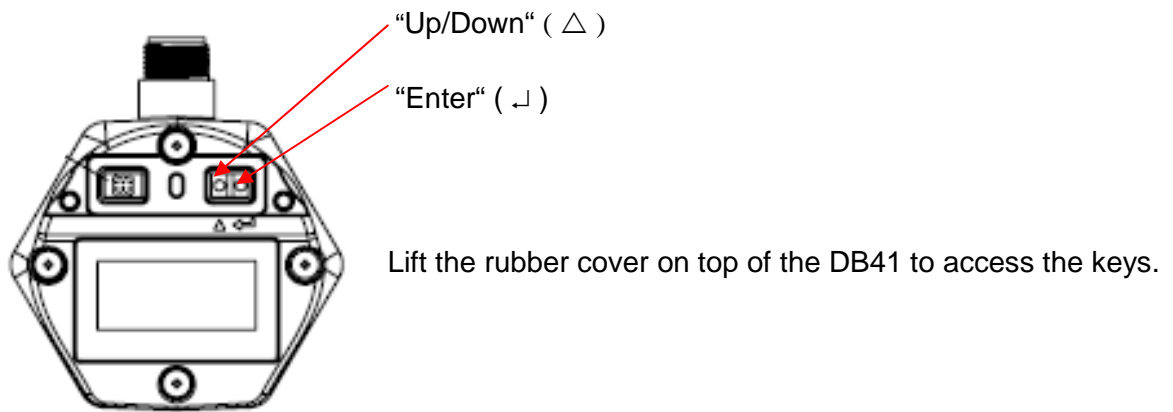

**Normal display function**

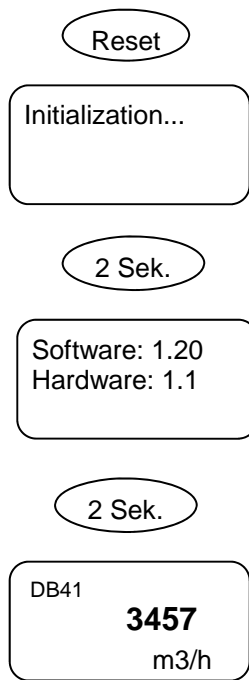

After power on, the display will go through an initialisation procedure and will show finally the actual on-line values.

Ex factory the DB41 is programmed to show volume flow and total consumption. Via the configuration menu up to 3 channels can be configured for on-line display. The DB41 will toggle between the channels every 2 seconds

**Configuration setting**

The DB41 is usually configured ex factory according to the customer settings ordered. In case settings have to be changed, the user has to keep the Enter key (↵) pressed while powering up the device.

IS DS 300 connected?  
Yes / No

Enter "Yes" if there is a DS 300 connected to the DB41, otherwise "No". Confirm setting with Enter key (↵).

Display 1  
Volume flow

The DB41 can display up to 3 channels, which are volumetric flow or mass flow, velocity and total consumption. Use the Up/down key (△) to select the desired channel. If no further channel is wanted, please select "nothing". The channels are toggled during normal operation mode every 2 seconds.

Consumption  
3457

In this step the total consumption counter can be reset to zero.

Contrast setting  
Up change  
Enter OK

Display contrast can be adjusted.

Save changes  
No Yes

Press Enter key (↵) to confirm the setting changes or press Up/down key (△) to discard all changes.

---

## WARRANTY

---

If you have reason for complaint we will of course repair any faults free of charge if it can be proven that they are manufacturing faults. The fault should be reported immediately after it has been found and within the warranty time guaranteed by us. Excluded from this warranty is damage caused by improper use and non adherence to the instruction manual.

The warranty is also cancelled once the instrument has been opened - as far as this has not been mentioned in the instruction manual for maintenance purposes - or if the serial number in the instrument has been changed, damaged or removed.

The warranty time for the DB41 is 12 months. If no other definitions are given the accessory parts have a warranty time of 6 months. Warranty services do not extend the warranty time.

If in addition to the warranty service necessary repairs, adjustments or similar are carried out the warranty services are free of charge but there is a charge for other services such as transport and packaging costs. Other claims, especially those for damage occurring outside the instrument, are not included unless responsibility is legally binding.

### **After sales service after the warranty time has elapsed**

We are of course there for you even after the warranty time has elapsed. In case of malfunctions please send us the instrument with a short-form description of the fault. Please do not forget to indicate your telephone number so that we can call you in case of any questions.

---

## ORDERING DATA

---

<b>Order no.</b>	<b>Description</b>
DB41.08	DB41 consumption counter with integrated 1/4" measuring section
DB41.15	DB41 consumption counter with integrated 1/2" measuring section
DB41.20	DB41 consumption counter with integrated 3/4" measuring section
DB41.25	DB41 consumption counter with integrated 1" measuring section
DB41.40	DB41 consumption counter with integrated 1 1/2" measuring section
DB41-Z.L5	Connection cable, 5 m, with M12 plug
DB41-Z.L10	Connection cable, 10 m, with M12 plug
DB41.xx.K	5 point precision calibration
DB41-Z.N	Mains adapter in wall housing 230 VAC/24 VDC

# DB41

## Compact thermal mass flow meter and counter for compressed air and non-aggressive gases

- **integrated upstream and downstream pipe runs for high levels of accuracy**
- **available for ¼" to 1 ½" pipe sizes**
- **measuring ranges:  
0.8–90 NI/min  
to 1.8–400 Nm<sup>3</sup>/h**
- **local LCD display for flow rate and total**
- **output signals: 4 to 20 mA for flow rate, pulses for totalization**



### Description:

Model DB41 thermal mass flow meters and counters report and measure mass flow rates and totals of non-aggressive gases, regardless of gas pressure and temperature. Process gas flows around a heated temperature sensor that is encapsulated in glass. As a result, the sensor dissipates heat which an electronics module returns to the sensor to maintain it at a constant temperature. The dissipated heat energy is proportional to the mass flow rate of the gas and is displayed by the electronic analyzer utilizing calibration curves and process parameters stored in the instrument. A 4 to 20 mA signal outputs the flow rate to secondary evaluation devices and a pulse output with a pre-defined pulse value provides a totalizing function. High levels of accuracy are obtained by means of upstream and downstream pipe runs integrated in the instrument which ensure that the flow stream is laminar.

### Typical Applications:

Series DB41 thermal mass flow meters and counters provide flow measurement of non-aggressive gases in ¼" to 1 ½" pipe systems. Their rugged, heavy-duty design and easy handling and operation make them the right choice for measuring and monitoring compressed air consumption. They also provide measurements of other suitable gases such as: nitrogen oxygen, argon, helium and carbon dioxide.

## Models:

**DB41...:** Thermal mass flow meters and counters for gases with integrated upstream and downstream pipe runs made of stainless steel 1.4301

## Measuring ranges:

Process connection (G or NPT)	Pipe ID (mm)	Measuring range	Length of device pipe section (mm)
1/4"	8.8	0.8 to 90 NI/min	194
1/2"	16.1	0.2 to 80 Nm <sup>3</sup> /h	324
3/4"	21.7	0.2 to 140 Nm <sup>3</sup> /h	439
1"	27.3	0.2 to 240 Nm <sup>3</sup> /h	549
1 1/2"	41.8	1.8 to 400 Nm <sup>3</sup> /h	839

## Dimensions:

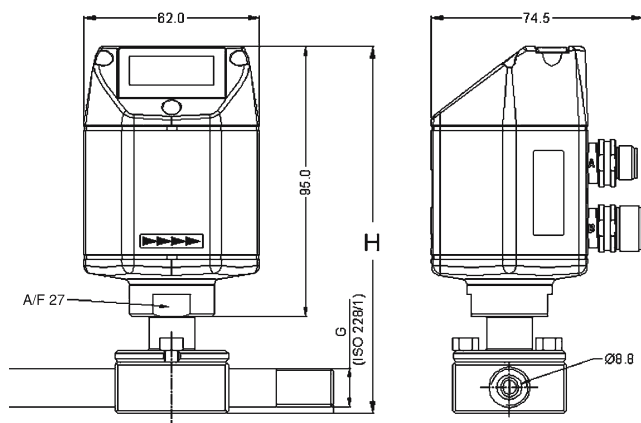

Pipe size (D)	1/4"	1/2"	3/4"	1"	1 1/2"
Height (H) (mm)	129	136	143	151	171

## Electrical Connection:

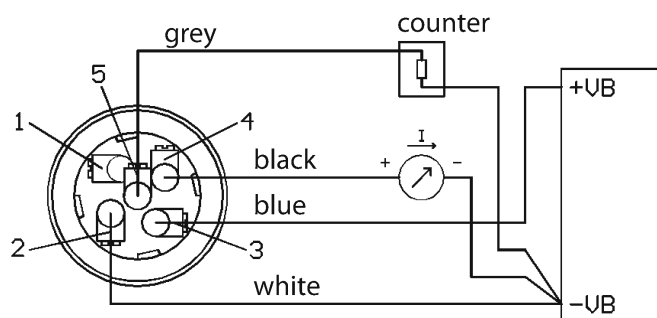

## Ordering Code:

**Order Number:** DB41. G. 15. L. 0

**Thermal mass flow meters and counters for gases with integral upstream and downstream pipe runs**

### Model:

G = G male thread  
N = NPT male thread

### Measuring range and pipe size:

08 = 0.8 to 90 NI/min, 1/4"  
15 = 0.2 to 80 Nm<sup>3</sup>/h, 1/2"  
20 = 0.2 to 140 Nm<sup>3</sup>/h, 3/4"  
25 = 0.2 to 240 Nm<sup>3</sup>/h, 1"  
40 = 1.8 to 400 Nm<sup>3</sup>/h, 1 1/2"

### Process gas:

L = air  
N = nitrogen  
A = argon  
H = helium  
C = carbon dioxide  
S = oxygen

### Options:

0 = none  
9 = please specify in writing

## Accessories :

- DB41-Z.L5** 5 m cable with matching plug
- DB41-Z.L10** 10 m cable with matching plug
- DB41-Z.N1** Wall mounted power supply, 100-240 VAC, 10 VA on 24 VDC, 0.35 A
- DB41-Z.N2** plug-in power supply, 100-240 VAC on 24 VDC, 0.35 A, with 2 m cable
- DB41-Z.K5** factory calibration, 5 measuring points

## Technical Specifications:

- max. pressure:** 16 bar
- Process gas temperature:** -30 to +80 °C
- Measurement uncertainty:** ± 3% of measured value (± 2% with factory calibration)
- Measuring ranges and nominal sizes:** refer to "Ordering Code" section
- Mounting position:** any
- Voltage supply:** 24 VDC
- Outputs :** 4 to 20 mA (max. load 500 ohm), pulses (1 pulse/L for DB41...08 or 1 pulse/m<sup>3</sup> for DB41...15 to 40, other pulse values available on request)
- Display :** LCD, for flow rate and total (NI/min for DB41...08 or Nm<sup>3</sup>/h for DB41...15 to 40, other units available on request)
- Electrical protection:** IP65